

50G

Compact Excavator



JOHN DEERE





50G COMPACT EXCAVATOR

SMALLER MACHINE, BIGGER POTENTIAL

When you need more from your compact excavator, the John Deere 50G might be your “one and done.” This small-but-mighty muscle specializes in making work in close quarters seem like no big deal. Loaded with customer-inspired ideas like significant lift and reach, precise control, and an amazingly comfortable cab, digging, excavating, and loading tasks become big possibilities. Plus it runs quiet, too. Jobsite-proven standard and optional advantages including your choice of tracks and John Deere attachments push the 50G to make a sizable impact on the potential — and profitability — of your operation.

FEATURES



Start from zero

Zero-tail-swing design maximizes maneuverability and performance in tight places such as urban and residential areas. Compact stature enables easy transport between jobsites, perfect for “dig-and-go” projects.

Resource management

Auto-idle automatically reduces engine speed when hydraulics aren't in use. Auto shutdown conserves precious fuel. Power/economy modes optimize power for digging applications, further improving fuel efficiency.

Get back to it

Standard backfill blade enables the 50G to grade and fill, boosting machine versatility and stability when using attachments or working on uneven terrain.

Comfort, quiet, and control

Spacious operator station has a wide entryway and backhoe- to excavator-style controls. Swing boom and foldable travel pedals are positioned for efficient operation and comfortable foot room. Noise-reducing aftertreatment device and isochronous high-idle speed help keep things noticeably quiet. Rubber cab mounts isolate the operator from noise and vibration.

Swing for the fences

Put the 50G's independent-swing boom and 360-degree rotation to work taming difficult tasks. Impressive lift height and reach ease truck loading.



**RUBBER CAB MOUNTS
HELP ISOLATE OPERATOR
FROM NOISE & VIBRATION**

Handy hydraulics

Standard quick-coupler-equipped, boom-mounted auxiliary hydraulic lines simplify attachment hookup. Return-flow selector valve accommodates hydraulic-driven attachments that operate either one or two ways. Wedge-style coupler enables swift changes of a wide range of buckets and attachments, such as hydraulic hammers, plate compactors, and augers.

Safe travels

No operator activation is required for high-speed travel. Track speeds automatically slow to low whenever a heavier load is encountered, then return to high when the load normalizes.

Designed for durability

Heavy-duty side shields deflect material and impacts, protecting boom/blade cylinders and drive motors. Single-pin swingpost increases boom rigidity. Reinforced D-channel side frames and heavy-duty X-frame help extend wear life.

Maintenance made easy

Hinged door provides wide-open access to the side-by-side oil cooler and radiator. Operator station tilts forward 50 degrees to reach the swing motor, hydraulic control valve, engine starter motor, and alternator. Extended service intervals allow the machine to work longer before maintenance is needed.

Make the most of your investment

Already own some John Deere attachments? Many models including buckets, hydraulic hammers, and augers also work on other compact machines so you can redefine fleet utilization — and your bottom line.



50G COMPACT EXCAVATOR



MATCH YOUR TRACK TO THE APPLICATION

The choice is yours

Rubber tracks traverse virtually any terrain, including paved surfaces. Optional rubber grousers combine work-anywhere flexibility with steel-track serviceability. Steel tracks and steel tracks with rubber pads are also available.

Remote diagnostics and support

To maximize uptime and lower costs, JDLink™ connectivity provides machine location, utilization data, and alerts to help you maximize productivity and efficiency. JDLink also enables John Deere Connected Support™. Dealers use Expert Alerts based on data from thousands of connected machines to proactively address conditions that may otherwise likely lead to downtime. Your dealer can also monitor machine health and leverage remote diagnostics and programming capability to further diagnose problems and even update machine software without a time-consuming trip to the jobsite.*

*Availability varies by region. Options not available in every country.



50G COMPACT EXCAVATOR SPECIFICATIONS

Engine		50G	
Manufacturer and Model	Yanmar 4TNV88C	Displacement	2.19 L (134 cu. in.)
Non-Road Emission Standard	EPA Final Tier 4/EU Stage IV	Net Power (ISO 9249)	26.8 kW (35.9 hp) at 2,400 rpm
Powertrain			
Each track independently driven by hydrostatic axial-piston motor connected to 2-stage planetary gear-reduction box			
Maximum Travel Speed	Low: 2.5 km/h (1.6 mph) / High: 4.2 km/h (2.6 mph)		
Hydraulics			
Closed-center load sensing with 1 variable-displacement pump			
Pump Flow	120.0 L/m (31.7 gpm)	Controls	Hydraulic pilot-operated controls for boom, arm, bucket, swing, boom swing, blade, travel, and auxiliary functions
Auxiliary Flow	87.4 L/m (23.1 gpm)		
Electrical			
Alternator Rating	55 amp		
Work Lights	2 halogen: 1 mounted on operator's station and 1 mounted on boom		
Undercarriage			
Track, Rubber	400 mm (16 in.)		
Ground Pressure			
	<i>1380-mm (4 ft. 6 in.) Standard Arm and Standard Counterweight</i>	<i>1690-mm (5 ft. 7 in.) Long Arm and Extra Counterweight</i>	
	<i>With Canopy</i>	<i>With Cab</i>	
With Rubber Track	26.9 kPa (3.90 psi)	28.3 kPa (4.10 psi)	28.8 kPa (4.17 psi)
			<i>With Canopy</i>
			<i>With Cab</i>
			29.5 kPa (4.28 psi)
Upperstructure			
Swing Speed	9.0 rpm		
Independent Swing Boom			
Left	80 deg.		
Right	60 deg.		
Swing Brake	Spring applied, hydraulically released, automatic, disc type		
Serviceability			
Refill Capacities		Refill Capacities (continued)	
Fuel Tank	70 L (18.5 gal.)	Engine Oil With Filter	8.6 L (9.1 qt.)
Cooling System	5.0 L (5.3 qt.)	Hydraulic Tank	56 L (14.8 gal.)
Operating Weights			
	<i>1380-mm (4 ft. 6 in.) Standard Arm and Standard Counterweight</i>	<i>1690-mm (5 ft. 7 in.) Long Arm and Extra Counterweight</i>	
	<i>With Canopy</i>	<i>With Cab</i>	
With 400-mm (16 in.) Rubber Track, Straight Blade, Full Fuel Tank, and 79-kg (175 lb.) Operator	4790 kg (10,560 lb.)	4920 kg (10,847 lb.)	5018 kg (11,063 lb.)
Optional Angle Blade	409 kg (902 lb.)	409 kg (902 lb.)	409 kg (902 lb.)
Counterweight			
Standard	700 kg (1,543 lb.)	700 kg (1,543 lb.)	700 kg (1,543 lb.)
Additional	200 kg (441 lb.)	200 kg (441 lb.)	200 kg (441 lb.)
Operating Dimensions			
	<i>1380-mm (4 ft. 6 in.) Standard Arm and Canopy</i>	<i>1380-mm (4 ft. 6 in.) Standard Arm and Cab</i>	<i>1690-mm (5 ft. 7 in.) Long Arm and Canopy</i>
			<i>Long Arm and Cab</i>
A Maximum Cutting Height	5.75 m (18 ft. 10 in.)	5.75 m (18 ft. 10 in.)	6.00 m (19 ft. 8 in.)
B Maximum Dumping Height	4.07 m (13 ft. 4 in.)	4.07 m (13 ft. 4 in.)	4.31 m (14 ft. 2 in.)
C Maximum Digging Depth	3.53 m (11 ft. 7 in.)	3.53 m (11 ft. 7 in.)	3.83 m (12 ft. 7 in.)
D Maximum Digging Reach	5.96 m (19 ft. 7 in.)	5.96 m (19 ft. 7 in.)	6.26 m (20 ft. 6 in.)
E Minimum Front Swing Radius	2.21 m (7 ft. 3 in.)	2.21 m (7 ft. 3 in.)	2.30 m (7 ft. 7 in.)
F Transport Length	5.47 m (17 ft. 11 in.)	5.47 m (17 ft. 11 in.)	5.52 m (18 ft. 1 in.)
Digging Force (ISO)			
Arm	24.0 kN (5,401 lb.)	24.0 kN (5,401 lb.)	21.0 kN (4,718 lb.)
Bucket	36.8 kN (8,267 lb.)	36.8 kN (8,267 lb.)	36.8 kN (8,267 lb.)

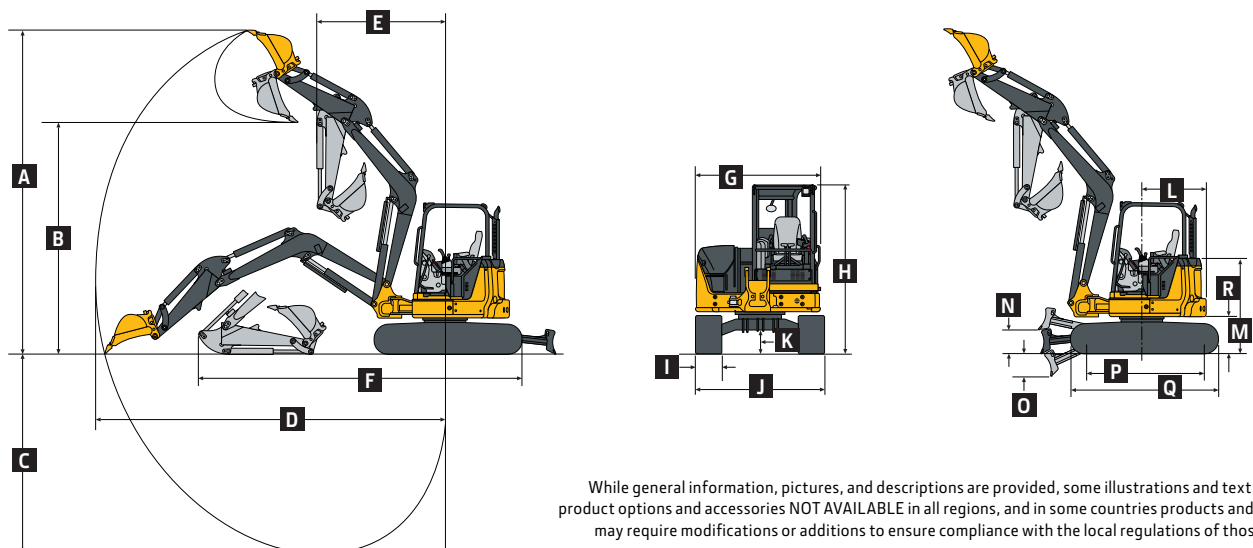

While general information, pictures, and descriptions are provided, some illustrations and text may include product options and accessories NOT AVAILABLE in all regions, and in some countries products and accessories may require modifications or additions to ensure compliance with the local regulations of those countries.

Machine Dimensions (see line art at bottom right of page 6)		50G	
G Upperstructure Width	1.85 m (6 ft. 1 in.)	M Engine Cover Height	1.59 m (5 ft. 3 in.)
H Overall Height		N Maximum Blade Lift Above Ground	460 mm (18 in.)
Canopy	2.53 m (8 ft. 4 in.)	O Maximum Blade Drop Below Ground	360 mm (14 in.)
Cab	2.53 m (8 ft. 4 in.)	Blade	
I Track Width	400 mm (16 in.)	Width	2.00 m (6 ft. 7 in.)
J Undercarriage Width	2.00 m (6 ft. 7 in.)	Height	375 mm (15 in.)
K Ground Clearance	340 mm (13 in.)	P Sprocket Center to Idler Center	2.00 m (6 ft. 7 in.)
L Tail Swing Radius		Q Track Length	2.50 m (8 ft. 2 in.)
With Standard Arm	1.00 m (39 in.)	R Counterweight Clearance	610 mm (24 in.)
With Long Arm and Extra Counterweight	1.10 m (43 in.)		

Lift Capacities

Boldface type indicates hydraulically limited capacity; lightface type indicates stability-limited capacities, in kg (lb.). All lift capacities are based on ISO 10567 (with power boost). Lifting measurement from center of arm to bucket pin with 100-mm (4 in.) track shoe and blade on ground and situated on firm, level, uniform supporting surface. Total load includes weight of cables, hook, etc. Figures do not exceed 87 percent of hydraulic capacities or 75 percent of weight needed to tip machine.

Ground Level at 3.05-m (10 ft.) Radius	Canopy and Standard Counterweight		Cab and Standard Counterweight		Canopy and Extra Counterweight		Cab and Extra Counterweight	
	Over Front*	Over Side	Over Front*	Over Side	Over Front*	Over Side	Over Front*	Over Side
1380-mm (4 ft. 6 in.) Standard Arm	2511 kg (5,531 lb.)	1110 kg (2,444 lb.)	2511 kg (5,531 lb.)	1150 kg (2,534 lb.)	2511 kg (5,531 lb.)	1232 kg (2,714 lb.)	2511 kg (5,531 lb.)	1273 kg (2,803 lb.)
1690-mm (5 ft. 7 in.) Long Arm	2477 kg (5,456 lb.)	1088 kg (2,396 lb.)	2477 kg (5,456 lb.)	1129 kg (2,486 lb.)	2477 kg (5,456 lb.)	1210 kg (2,666 lb.)	2477 kg (5,456 lb.)	1251 kg (2,755 lb.)

*Blade down (limited by hydraulics).

Additional equipment

Key: ● Standard ▲ Optional or special

See your John Deere dealer for further information.

50G Engine
● Meets EPA Final Tier 4/EU Stage IV emissions
● Auto shutdown
● Engine coolant to -37 deg. C (-34 deg. F)
● Engine preheater
● Fan guard
● Fuel/water separator
● Full-flow oil filter
● Isolation mounted
● Key start switch with electric fuel shutoff
● Single dry-type air filter
Hydraulic System
● Auto-idle
● Auxiliary function right-hand pilot-lever control
● Auxiliary hydraulic lines with quick-couplers to end of boom
● Auxiliary return-flow selector valve
● Axial-piston swing motor
● Boom-swing foot control
● Excavator-to-backhoe control pattern change valve
● Closed center load sensing with 1 variable-displacement pump
● Hydraulic pilot-operated controls for boom, arm, bucket, swing, boom swing, blade, travel, and auxiliary functions
● Wet-disc swing brake
Undercarriage
● Planetary final drive
● Propel motor shield
● 2-speed axial-piston propel motors

50G Undercarriage (continued)
● Rubber track, 400 mm (16 in.)
▲ Steel track, 400 mm (16 in.) with triple semi-grousers
▲ Rubber crawler pad, 400 mm (16 in.)
Upperstructure
● 360-deg. rotation
● Counterweight, 700 kg (1,543 lb.)
● Hinged service-access doors
● Toolbox
● ROPS/TOPS/FOPS (canopy)
▲ ROPS/TOPS/FOPS (cab) with air conditioning and heater
● Vandal protection for service doors, fuel cap, and toolbox
● Zero-tail-swing configuration
Front Attachments
● Arm, 1380 mm (4 ft. 6 in.)
▲ Long arm, 1690 mm (5 ft. 7 in.), includes additional 200-kg (441 lb.) counterweight
● Articulation hose shield
● Backfill blade, 1.00 m (3 ft. 3 in.)
▲ Hydraulic angle backfill blade
● Boom, 2.85 m (9 ft. 4.2 in.)
● Mechanical quick-coupler
▲ Augers: Planetary / Chain drive / Bits / Bit adapters
▲ Clamp
▲ Hammers: Points / Tools
▲ Quick-coupler buckets: Bucket teeth / Ditching / Heavy-duty

50G Operator's Station
● Horn
● Hour meter
● Instrumentation lights
● Mode selectors (illuminated): Power mode (I) / Economy mode (II)
● Monitor system: Preheat indicator / Engine oil pressure indicator with alarm / Alternator voltage indicator / Fuel gauge and low-fuel-level indicator / Engine coolant temperature gauge and engine coolant temperature indicator with alarm / Hour meter / Work lights indicator
● Motion alarm with cancel switch
● Work lights switch
● Propel levers and foldable pedals
● 2 travel speeds with automatic shifting
● Seat belt, 51 mm (2 in.), retractable
▲ Seat belt, 76 mm (3 in.), retractable
● Vinyl seat with fore/aft adjustment
▲ Suspension seat (cloth)
▲ Front screen
▲ Rear secondary exit kit
Electrical
● 12-volt accessory outlet
● Alternator, 55 amp
● Low-maintenance battery
● Blade-type multi-fused circuits
● Positive-terminal battery covers
Lights
● Work lights: Halogen / 1 mounted on operator's station / 1 mounted on boom

While general information, pictures, and descriptions are provided, some illustrations and text may include product options and accessories NOT AVAILABLE in all regions, and in some countries products and accessories may require modifications or additions to ensure compliance with the local regulations of those countries.

Net engine power is with standard equipment including air cleaner, exhaust system, alternator, and cooling fan at test conditions per ISO 9249. These machines are not equipped with spark-arrestor mufflers. Usage in forestry applications is not recommended. Specifications and design subject to change without notice. Wherever applicable, specifications are in accordance with SAE standards. Except where otherwise noted, these specifications are based on a canopy unit with standard arm; 610-mm (24 in.), 0.16-m³ (5.7 cu. ft.) bucket; 400-mm (16 in.) rubber track; and 700-kg (1,543 lb.) counterweight; full fuel tank; and 79-kg (175 lb.) operator.



DKAXG50 (22-10)



JOHN DEERE