

325G

Compact Track Loader



JOHN DEERE





GET ON THE WINNING TRACK

When we asked owners and operators like you — the ones who run them — for your ideas on what makes a great compact track loader, you helped us redefine our proven G-Series models. You wanted more power under the hood. And increased lift height, reach, stability, and breakout force. Plus optional LED side lighting, rearview camera, ride control, and high-flow auxiliary hydraulics to power attachments like never before. Putting us through the paces has helped put the 325G on track for even more performance — and your operation in the running for some pretty big wins.

325G COMPACT TRACK LOADER

FEATURES



Elevating expectations

Vertical-lift boom combines height and reach at the top of the lift path with outstanding stability. Along with a rated operating capacity of nearly 2,600 pounds, the 325G can precisely place pallets and muscle heavy materials.

Armed forces

Extreme pushing power and bucket breakout forces deliver the tractive effort and leverage to carve out clay, plow through piles, and handle large loads.

Have speed, will travel

Standard two-speed transmission delivers travel speeds of just over eight miles per hour, for rapid work cycles and quick trips around the jobsite.

Load warrior

Height to hinge pin of 10 feet 6 inches enables the 325G to easily load tandem-axle dump trucks, fill hoppers, and feed mixers. Additional reach to truck-bed height comes in handy for moving pallets of pavers or other weighty cargo.



RELIABLE



PRODUCTIVE

Controls that work your way

Electrohydraulic (EH) ISO-pattern joystick controls that allow customized machine operations based on operator preference are standard. ISO-H switchable joystick controls and EH joystick performance package featuring creep control and boom- and bucket-speed settings are optional.

Packed for productivity

Low center of gravity, 34-degree bucket rollback, optional ride control, and optional hydraulic self-leveling help keep forks loaded and buckets full. Add capacity with up to three sets of rear counterweights.

Room with a view

Large cab entryway with swing-out door, generous foot- and legroom, sealing and pressurization to minimize dust and noise, and deluxe vinyl suspension seat optimize operator comfort. Easy-to-read LCD monitor reveals a wealth of vital operating info and advanced diagnostics. Sliding/locking glass side windows can be easily removed for cleaning.

Seeing is believing

Clear sightlines to the cutting edge and bucket corners, above and below the lift arms, and the jobsite ahead and behind instill confidence in close quarters. Optional LED side lighting and rearview camera further enhance visibility.

Within easy reach

Tilt the hood up for convenient ground-level access to the dipstick, filters, and fuel and fluid fills. Neat freacks and rental yards can appreciate the convenient cab-footwell access that helps speed cleaning.



325G COMPACT TRACK LOADER



SWITCHING ATTACHMENTS ENABLES VERSATILITY IN ANY WEATHER OR SEASON

Make the connection

Equip your CTL with your choice of over 100 available John Deere attachments to expand the flexibility of your operation. Increased auxiliary hydraulic flow and power compared to previous models boosts attachment performance. Add a snow blower, snow pusher, or angle broom to make quick work of winter's white stuff.

Safety first

Standard personal-protection features include in-cab-activated boom lock and triple-interlock system that detects the presence of the operator to help keep harm's way at bay.

Remote diagnostics and support

To maximize uptime and lower costs, JDLink™ connectivity provides machine location, utilization data, and alerts to help you maximize productivity and efficiency. JDLink also enables John Deere Connected Support™. Dealers use Expert Alerts based on data from thousands of connected machines to proactively address conditions that may otherwise likely lead to downtime. Your dealer can also monitor machine health and leverage remote diagnostics and programming capability to further diagnose problems and even update machine software without a time-consuming trip to the jobsite.*

*Availability varies by region. Options not available in every country.



325G

COMPACT TRACK LOADER SPECIFICATIONS

Engine		325G	
Manufacturer and Model	Yanmar 4TNV98CT	Displacement	3.3 L (203 cu. in.)
Non-Road Emission Standard	EPA Final Tier 4/EU Stage IV	Rated Engine Speed	2,500 rpm
Cylinders	4	Torque Rise	34% at 1,800 rpm
Gross Rated Power (ISO 14396)	54.8 kW (74 hp) at 2,500 rpm	Aspiration	Turbocharged
Net Power (SAE J1349 / ISO 9249)	52.5 kW (70 hp) at 2,500 rpm	Air Cleaner	Dry dual element
Peak Torque	280 Nm (207 lb.-ft.) at 1,800 rpm		
Cooling			
Fan Type	Variable-speed hydraulic drive standard / reversing fan drive optional		
Powertrain			
Pump	Axial-piston hydrostatic	Travel Speeds (<i>continued</i>)	
Controls	Electrohydraulic	2 Speed, High	13.2 km/h (8.2 mph)
Travel Speeds		Brake	Integral, automatic, spring-applied, hydraulically released wet-disc brake
2 Speed, Low	8.4 km/h (5.2 mph)		
Undercarriage			
Rubber Tracks	New-Generation smooth-ride long-life rubber with steel inserts	Track Rollers (per side)	4 triple-flange smooth-ride all-steel rollers
Track Width		Track Idlers (per side)	2 double-flange smooth-ride all-steel rollers
Standard	320 mm (12.6 in.)	Bearings/Seals (rollers/idlers)	Heavy-duty journal bearings and metal face seals
Optional	400 mm (15.8 in.)	Tractive Effort	3859 kgf (8,500 lbf)
Ground Pressure			
With Standard 320-mm (12.6 in.) Track	39.3 kPa (5.7 psi)		
With Optional 400-mm (15.8 in.) Track	32.4 kPa (4.7 psi)		
Hydraulics			
Pump Flow		Hydraulic Horsepower Flow (calculated)	
Standard	78 L/m (21 gpm)	Standard	31.1 kW (41.7 hp)
Total With High-Flow Option	120 L/m (32 gpm)	High	47.4 kW (63.6 hp)
System Pressure at Couplers	23 787 kPa (3,450 psi)		
Cylinders			
Type	John Deere heat-treated, chrome-plated polished cylinder rods, hardened steel (replaceable bushings) pivot pins		
Electrical			
Voltage	12 volt		
Battery Capacity	750 CCA standard / 925 CCA optional		
Alternator Rating	75 amp		
Lights	Halogen, 2 front and 1 rear		
Operator's Station			
	ROPS (ISO 3471) / FOPS (ISO 3449) structure with quick-pivot standard		
Serviceability			
Refill Capacity			
Fuel Tank	79 L (21 gal.)		
Operating Weights			
With Standard 320-mm (12.6 in.) Track	4313 kg (9,500 lb.)		
With Optional 400-mm (15.8 in.) Track	4381 kg (9,650 lb.)		
Machine Dimensions			
A Length Without Bucket	2.85 m (112.3 in.) (9 ft. 4 in.)		
B Length With Foundry Bucket	3.46 m (136.3 in.) (11 ft. 4 in.)		
C Width Without Bucket			
With 320-mm (12.6 in.) Track	1.82 m (71.5 in.) (6 ft. 0 in.)		
With 400-mm (15.8 in.) Track	1.90 m (74.7 in.) (6 ft. 3 in.)		
D Height to Top of ROPS	2.06 m (81.1 in.) (6 ft. 9 in.)		
E Height to Hinge Pin	3.20 m (126.1 in.) (10 ft. 6 in.)		
F Dump Height With Foundry Bucket	2.59 m (102.1 in.) (8 ft. 6 in.)		
G Dump Reach			
With Foundry Bucket	0.75 m (29.7 in.)		
With Construction Bucket	0.94 m (37 in.) (3 ft. 1 in.) with edge		
H Ground Clearance	0.24 m (9.3 in.)		
I Angle of Departure	30.5 deg.		
J Front Turn Radius With Foundry Bucket	2.03 m (80 in.) (6 ft. 8 in.)		
K Dump Angle (full lift height)	41 deg.		
L Bucket Rollback (ground level)	34 deg.		

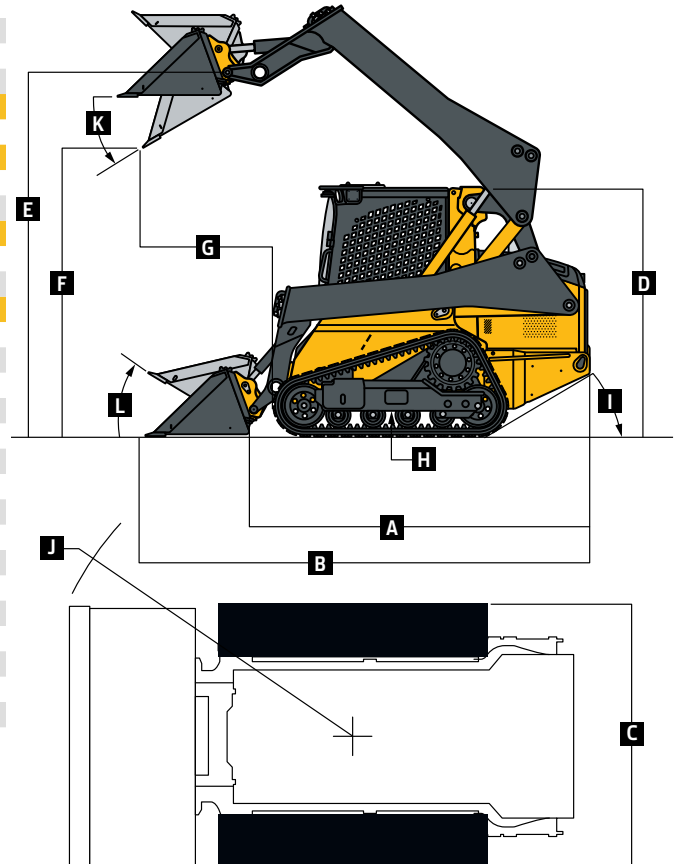

While general information, pictures, and descriptions are provided, some illustrations and text may include product options and accessories NOT AVAILABLE in all regions, and in some countries products and accessories may require modifications or additions to ensure compliance with the local regulations of those countries.

Loader Performance		325G	
Tipping Load	3360 kg (7,400 lb.) with foundry bucket	Boom Breakout Force <i>(continued)</i>	
SAE Rated Operating Capacity		With Construction Bucket	2157 kg (4,750 lb.)
At 35% Tipping Load	1176 kg (2,590 lb.) with foundry bucket	Bucket Breakout Force	
At 50% Tipping Load	1680 kg (3,700 lb.) with foundry bucket	With Foundry Bucket	3973 kg (8,750 lb.)
Boom Breakout Force		With Heavy-Duty Construction Bucket	2724 kg (6,000 lb.)
With Foundry Bucket	2384 kg (5,250 lb.)		

Additional equipment

Key: ● Standard ▲ Optional or special See your John Deere dealer for further information.

325G Engine

- Meets EPA Final Tier 4/EU Stage IV emissions
- ▲ Meets EPA Interim Tier 4/EU Stage IIIA emissions
- Yanmar 4TNV98CT
- ▲ Yanmar 4TNV98T
- Auto-idle
- Automatic fan tensioner
- Automatic preheat
- Electronic injection system
- ▲ Engine air precleaner kit
- Fuel tank, 79 L (21 gal.)
- John Deere COOL-GARD™ II Extended-Life Engine Coolant
- John Deere Plus-50™ 10w30 initial engine oil fill⁶
- 4-cylinder 54.8 kW (74 gross hp)/52.5 kW (70 net hp), 3.3-L (203 cu. in.) displacement
- 5-micron primary fuel filter and water separator
- ▲ Cold-weather starting package

Cooling System

- Coolant surge tank
- Variable-speed hydraulically driven fan cooling system
- ▲ Reversing fan drive

Powertrain

- High-torque heavy-duty planetary-reduction final drive
- Automatic spring-applied hydraulically released wet-disc park brake
- Wet-disc brakes
- Transmission, 2 speed

Hydraulic System

- John Deere hydraulic cylinders with cushioned boom cylinders
- John Deere heat-treated, chrome-plated cylinder rods with replaceable bushings
- Connect-under-pressure auxiliary couplers
- Quick-check hydraulic fluid-level sight glass
- 1,000-hour, 5-micron hydraulic filter
- ▲ High-flow hydraulics
- Axial-piston hydrostatic pump

Electrical

- Automatic engine/hydraulic shutdown protection system

325G Electrical *(continued)*

- Auxiliary hydraulics operator-presence system
- Courtesy lighting
- Deluxe instrumentation EMU with: Operator-selectable monitoring – Hour meter, engine rpm, battery voltage, diagnostics, EMU configuration, engine coolant temperature, hydraulic oil temperature / LED warning indicators – Glow plug, seat switch, seat belt, door open, auxiliary hydraulics, park brake engaged, 2-speed engaged, stop, low engine oil pressure, engine coolant over-temperature, battery not charging, air filter restriction, and hydraulic filter restriction
- ▲ Deluxe LED lighting package with additional cab-integrated side lights (2)
- Front and rear halogen work lights
- Triple-interlock operator-presence control system
- Backup alarm
- Battery, 750 CCA
- ▲ Battery, 925 CCA
- Horn
- ▲ Hazard warning lights
- ▲ Strobe light, amber

Operator's Station

- Deluxe cab headliner
- Electrohydraulic (EH) ISO-pattern joystick controls
- ▲ ISO-H switchable joystick controls and EH joystick performance package*
- Keyless-start sealed-switch module with integrated anti-theft system and operator memory preference settings
- Electronic push-button auxiliary controls
- Pull-down adjustable lap bar
- Quick-pivot ROPS
- Rear window
- Removable top window
- ▲ Sliding/locking/removable glass side windows
- ROPS/FOPS operator structure
- ▲ Glass cab enclosure
- Seat belt, 51 mm (2 in.), retractable
- ▲ Shoulder belt, 51 mm (2 in.) or 76 mm (3 in.)

325G Operator's Station *(continued)*

- ▲ Severe-duty cab door and wiper system
- Water-shedding deluxe vinyl suspension seat
- ▲ Air-ride cloth, heated seat
- ▲ Air-ride vinyl seat
- 12-volt power port / Dome light / Cargo storage / Beverage holder
- ▲ Air conditioning with heater/defroster
- ▲ AM/FM radio with auxiliary input and Bluetooth® for audio streaming
- ▲ Floor mat with left footrest
- Rearview mirror
- ▲ Rearview camera

Loader

- In-cab boom lockout to secure loader before exiting seat
- Patented John Deere Quik-Tatch™ (no grease required)
- ▲ Power Quik-Tatch
- Patented John Deere vertical-lift boom
- ▲ Hydraulic self-leveling on/off and ride control

Other

- Convenient front and rear tie-downs
- Environmental drains for all fluid reservoirs
- ▲ Chrome exhaust stack
- ▲ Engine oil/hydraulic fluid-sampling kit
- ▲ Forestry protection packages
- ▲ Heavy-duty rear grille
- ▲ Rear counterweights (available in sets of 1, 2, or 3), 78 kg (172 lb.) (each set)
- ▲ Single-point lift kit
- ▲ SMV sign kit
- ▲ Track, 320-mm (12.6 in.) wide
- ▲ Track, 400-mm (15.8 in.) wide
- ▲ JDLink™ wireless communication system (available in specific countries; see your dealer for details)

⁶500-hour engine oil-change intervals when John Deere Plus-50 oil and John Deere oil filter are used.

*EH joystick performance package features switchable accelerator/decelerator, selectable propel speeds, creep control, boom- and bucket-speed settings, and 12-volt 3- and 14-pin attachment-control harness with dash-mounted 4th-function rocker switch.

While general information, pictures, and descriptions are provided, some illustrations and text may include product options and accessories NOT AVAILABLE in all regions, and in some countries products and accessories may require modifications or additions to ensure compliance with the local regulations of those countries.

Net engine power is with standard equipment including air cleaner, exhaust system, alternator, and cooling fan, at standard conditions per SAE J1349 and DIN 6270B, using No. 2-D fuel at 35 API gravity. Gross power is without cooling fan. Specifications and design subject to change without notice. Wherever applicable, specifications are in accordance with SAE standards. Except where otherwise noted, these specifications are based on a unit with standard equipment, full fuel tank, and 79-kg (175-lb.) operator.



DKAGCTL325 (22-10)



JOHN DEERE