

# 9000 SERIES

PURE PERFORMANCE



**JOHN DEERE**

Nothing Runs Like a Deere™

# PURE PERFORMANCE

The 8000 Series raised the bar for quality forage harvesting – a true success story since day one. Building on that foundation and fueled by our ambition to help you produce more high-quality silage more efficiently – we present you the 9000 Series!

**THE EVOLUTION  
OF EXCELLENCE:  
9000 SERIES SPFH**



When you're ready to take things to the next level, the 9000 Series is your Self-Propelled Forage Harvester. Think top-of-the-line crop analysis and documentation capabilities, unparalleled forage quality with an exceptionally robust kernel processor – all powered by a true goliath of an engine with all the power anyone could ever need. Go ahead and take your business further.

## CONTENTS

 <b>ENGINE &amp; DRIVELINE</b>	 <b>CAB</b>
Engine & Cooling System ..... 8	Cab ..... 30
Driveline ..... 10	
 <b>CROP FLOW &amp; KERNEL PROCESSING</b>	 <b>INTELLIGENT SERVICES &amp; SOLUTIONS</b>
Crop Flow ..... 12	Services ..... 34
Cutterhead ..... 14	AutoTrac™ & RowSense™ ..... 36
Kernel Processing ..... 16	HarvestLab™ 3000 ..... 38
 <b>HEADERS</b>	 <b>CONNECTED FARM MANAGEMENT</b>
Headers ..... 18	Connected Farm Management ..... 44
 <b>TIRES &amp; PRODRIVE™</b>	 <b>SPECIFICATIONS</b>
Tires & ProDrive™ ..... 28	Specifications ..... 46

# MACHINE EVOLUTION

The 9000 Series is a direct result of our commitment to improve the harvesting process and forage quality for our customers.

## HARVESTMOTION

Our HarvestMotion concept blends pure performance and highest efficiency. It's a state-of-the-art engine with ideal performance characteristics and low specific fuel consumption at reduced rpm perfectly aligned and synchronized with a superior crop flow. This is our HarvestMotion concept for pure performance and highest efficiency.

### 9000 SERIES UP TO 970 PS\* (956 HP)

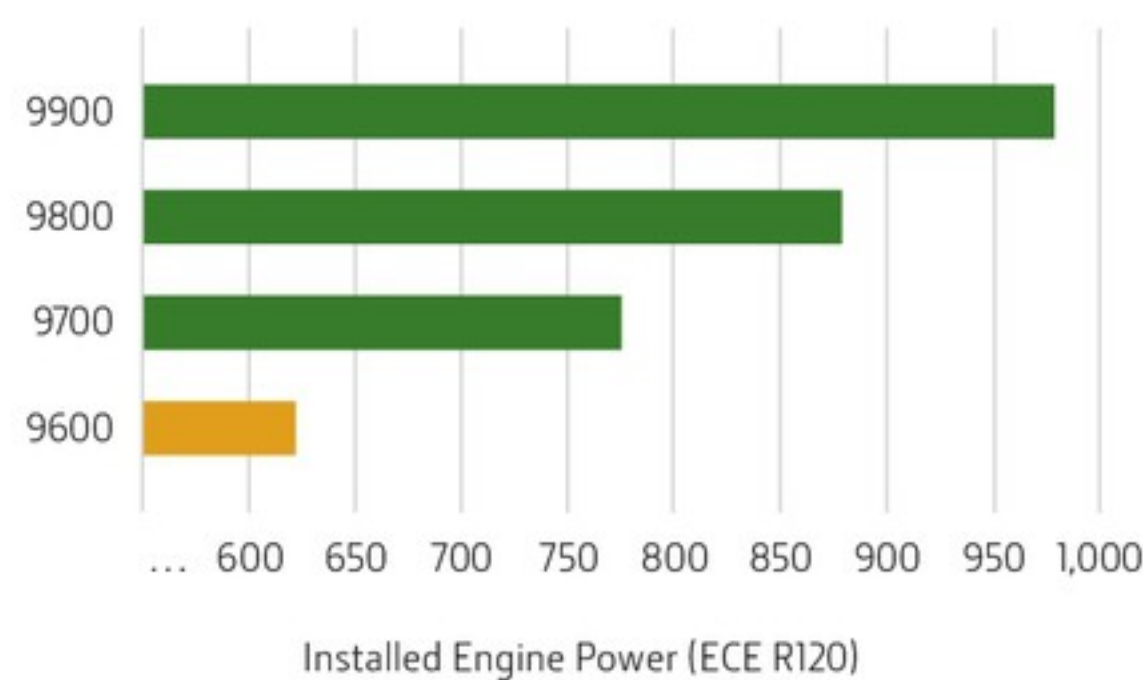

- Liebherr V12, 24.2 L
- PowerTech PSS, 13.5 L
- PowerTech PSS, 9 L

\*Industry ratings in Pferdestärke.

### 8000 SERIES UP TO 625 PS\* (616 HP)

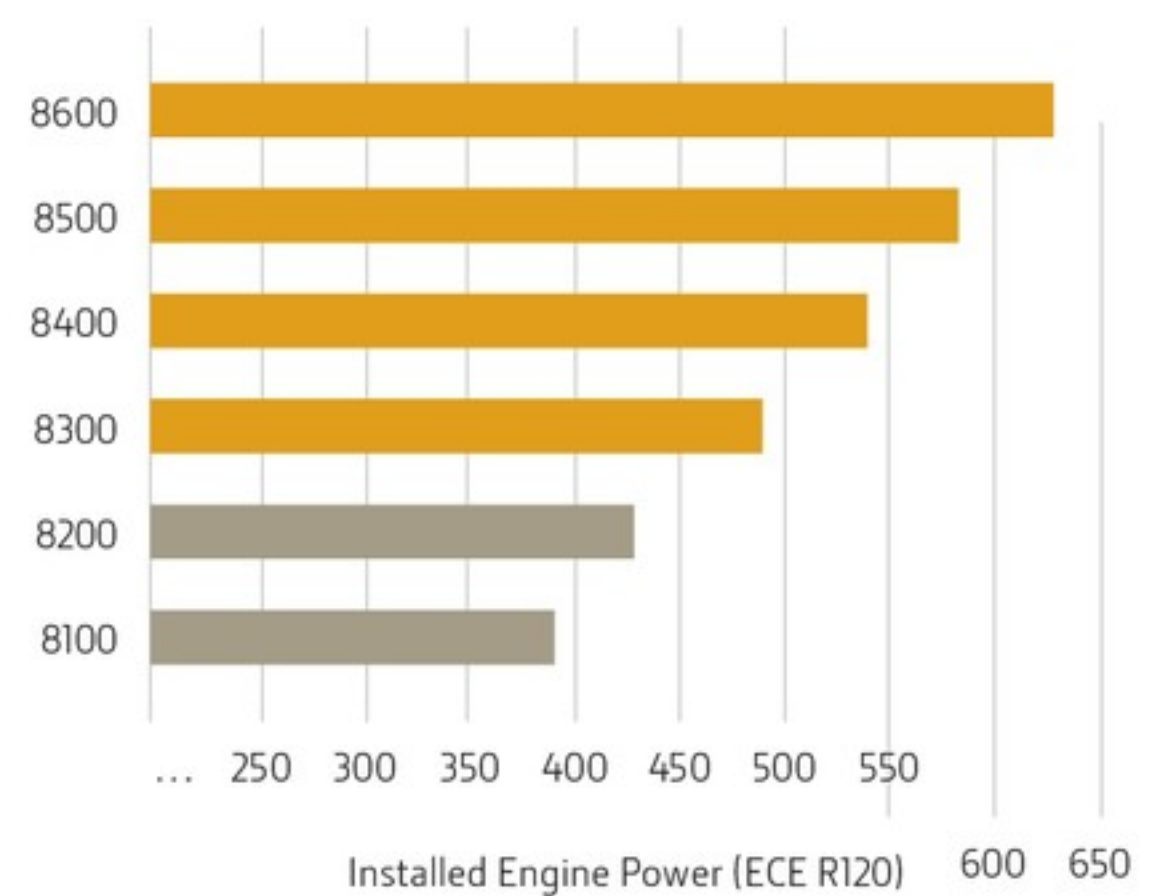



**ENHANCED, IMPROVED,  
EVEN BETTER:**

- Engine & Cooling
- Driveline
- Crop Flow
- Kernel Processing
- 772 Head
- Premium Pick-up

# EXCELLENCE EVOLVED

## OVERVIEW

The engine is the heart of a machine – that is especially true for the new 9000 Series, and that's where much of its productivity impact comes from. But it's more than just the engine.

Let us show you point-by-point how the renowned qualities of the 8000 Series combined with the innovations of the 9000 Series SPFH take these machines to the top rung of the evolutionary ladder.

**WE LOOKED AT  
EVERYTHING THAT  
WORKS GREAT. AND  
STARTED IMPROVING.**



## HARVESTMOTION

Our new performance concept adds significantly more throughput at optimized component speed for perfect power dynamics alignment at a low engine rpm resulting in low specific fuel consumption.

## INTELLIGENT FORAGE MANAGEMENT

HarvestLab™ 3000 measures and documents both dry matter and constituents in real-time for accurate silage quality analysis.

## FUNCTIONAL COMFORT CAB

It's built around you, with panoramic views, plenty of space and intuitive controls and displays.

## DYNAMIC CROP FLOW

We reduced intake losses to the absolute minimum, while our ProStream crop flow takes throughput per horsepower to a new level.

## EXTREME KERNEL PROCESSING

Get the proven JD Premium KP or opt for our new John Deere XStream™ KP for ideal processing results at any length of cut.

## DURA LINE™ LOW WEAR PARTS

Hard-wearing Dura Line crop flow liners and the extremely durable all-crop Dura Line Plus shearbars last for seasons.



### **MORE GRIP**

Up to 84.6-in. diameter reduced-weight tires with pressure down to 14 PSI deliver better traction with less compaction.

### **ALL POWER TO THE GROUND**

There's nothing like our ProDrive™ automatic transmission on the market – it puts the power where it counts.

### **HIGH-EFFICIENCY HEADERS**

Choose from a header range designed and engineered for high horsepower, excellent crop handling, and efficient and reliable operation.

### **LOWER COST OF OPERATION**

1,000-hour oil service intervals, fewer daily maintenance points and excellent access – it's how you keep costs down and productivity up.

# POWER CORE

## ENGINE & COOLING SYSTEM

More power, more throughput, more output. Get the productivity you've been looking for in extra heavy crop conditions.

The 9700, 9800 and 9900 models are equipped with a highly efficient 24.2 L Liebherr V12 engine, powering the machine with up to 956 hp. The 9600 features a John Deere PowerTech™ PSS engine with 13.5 L displacement. Mounted longitudinally, both engines feature perfect cooling efficiency with minimal fan requirements. Plus, they offer excellent serviceability and weight distribution. The bottom line: improved fuel efficiency, cleaner emissions and a massive amount of power at your disposal.



## COOLER BY DESIGN

The longitudinal layout of the 9000 Series engine eliminates the need for the large and power-intensive cooling packages that transverse engines require. More of the engine's surface area is closer to the outer edges of the machine, unobstructed by other components. Cool air is drawn in through the channels behind the cab and is guided along the sides of the engine to the exits at the rear and the sides. Bottom line: efficient cooling with fewer components.



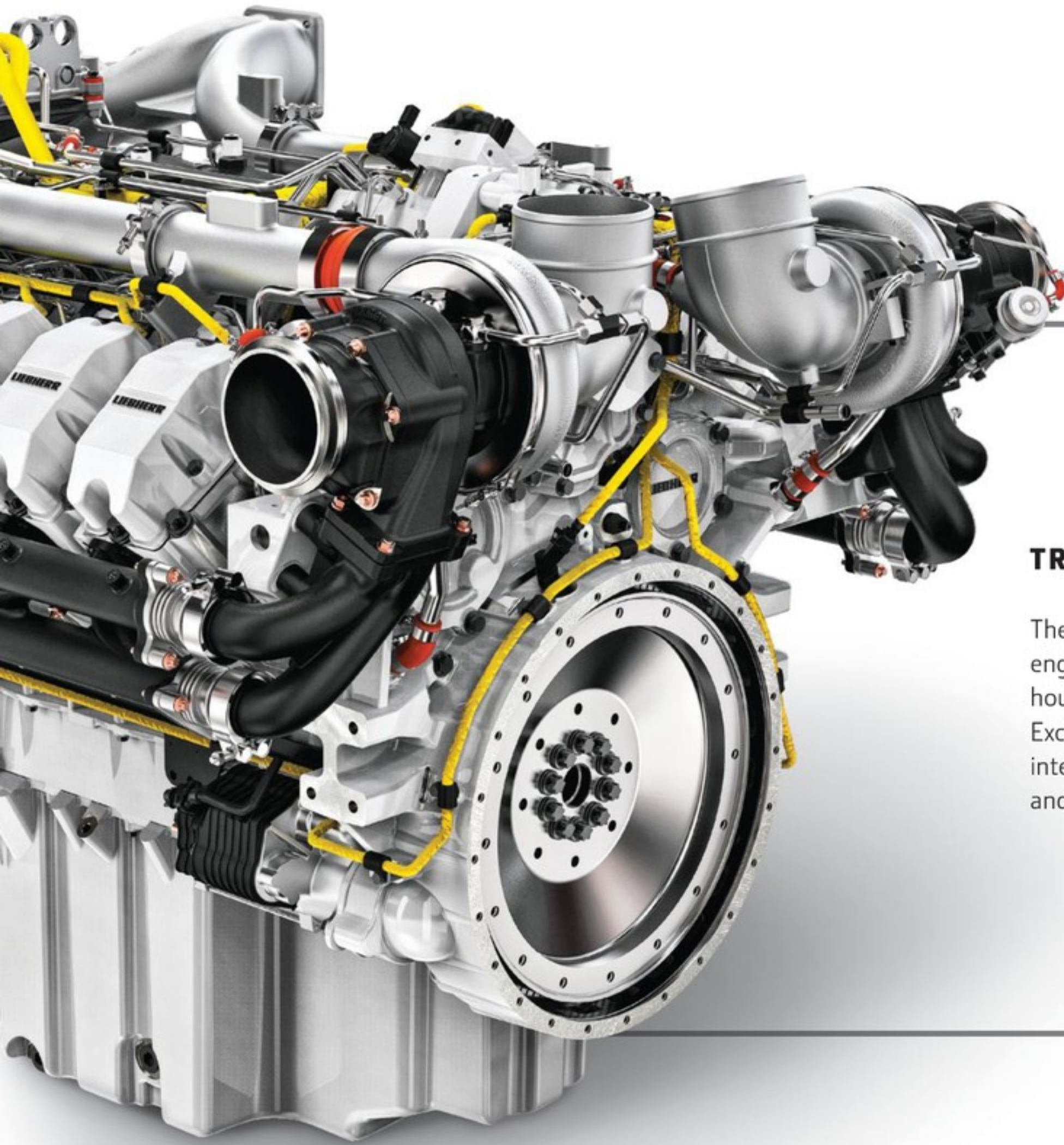

## TRIED AND TRUE

The new 24.2 L Liebherr V12 engine has extensive years and hours of testing under its belt. Exceptional 1,000-hour service intervals give you more uptime and fewer costs.

## STEADY POWER

Power – when you need it, where you need it. It's continuously available with the Liebherr engines in the 1,800-1,400 rpm range, with extra torque reserves below 1,400 rpm.

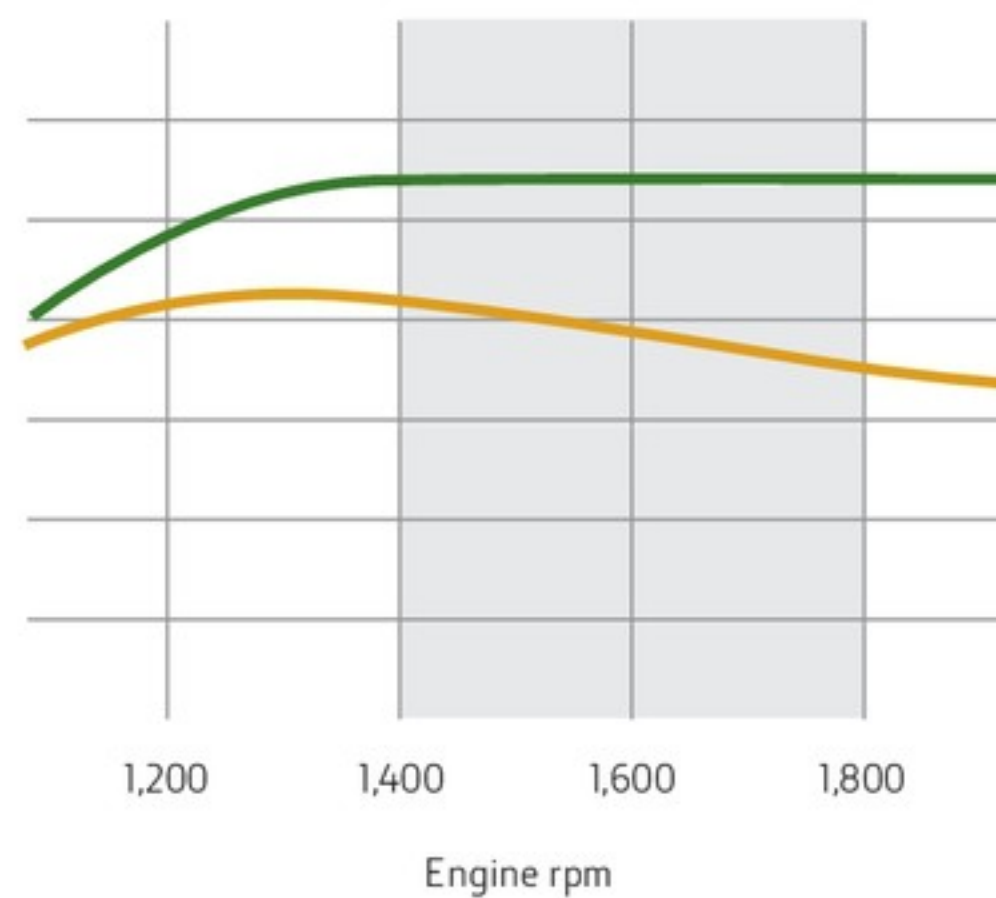

■ Power  
■ Torque

# EFFICIENCY BOOSTED

## DRIVELINE

Every single component of the 9000 Series driveline was designed to contribute to more efficiency. Crop flow components are powered by up to nine grooves to ensure the engine power available is transferred reliably to the main drive belt, and the kernel processor drive has had a significant upgrade as well. Overall fuel efficiency improves thanks to a lower driveline top speed of 1,800 rpm.

### LOWER RPM, LOWER COST

Efficient machines are simply good business. The 9000 Series driveline was specifically designed to deliver optimal crop flow right when the engine is operating in its efficiency sweet spot. That's HarvestMotion.

### OPTIMIZED HEADER DRIVE

You'll get even higher performance and throughput thanks to a larger hydrostatic drive, larger shaft diameter and bearings, and our new PTO. Of course, the gear ratio is matched exactly to the new engine power curve.

### NEW ENGINE INTEGRATION

Due to the compact and low integration of the Liebherr engine at the rear, less additional weight is needed to put power to the ground, which results in better fuel efficiency on the road and less soil compaction in the field.

### NEW LIGHTER MAIN CLUTCH

The new main clutch design incorporates some serious weight optimization to help reduce power losses and maximize overall fuel economy.

### MAIN FRAME DESIGN

The main frame was designed to accommodate larger headers and features new engine mountings for a lower center of gravity and to provide more space for an overall stronger driveline.





## HYDRAULICS SYSTEM ENHANCED

At its core is a sophisticated load-sensing system for maximum hydraulic performance with reduced losses and less pressure if needed. For optimized speeds, a hydraulic kernel processor belt tensioner comes standard.

## FEEDROLLS

We're sticking to the successful tried and tested design of the 8000 Series. We reinforced drives due to the higher engine power and throughput. For easier maintenance access, we made wear parts easier to reach under the side panel.

## HIGH-EFFICIENCY CROP STREAM

The straightforward design produces reliable and powerful material transport.

## FAST HEADER ATTACHMENT

The optional self-adjusting header locking system connects the driveline automatically.

## WIDE PROFILE KNIFE MOUNTINGS

The knife mountings are wider and the profile is designed to channel the crop for a more stable and even flow.

## QUICK STOP SYSTEM

Within 85 milliseconds, a hydraulic system instantaneously switches off the feedrolls without the stresses of traditional mechanical linkages.

## SMOOTH AND EVEN CROP FLOW

When you're chopping an uneven swath, our feedroll dampening system compensates and smooths out the crop mat for even feeding and consistent length of cut.

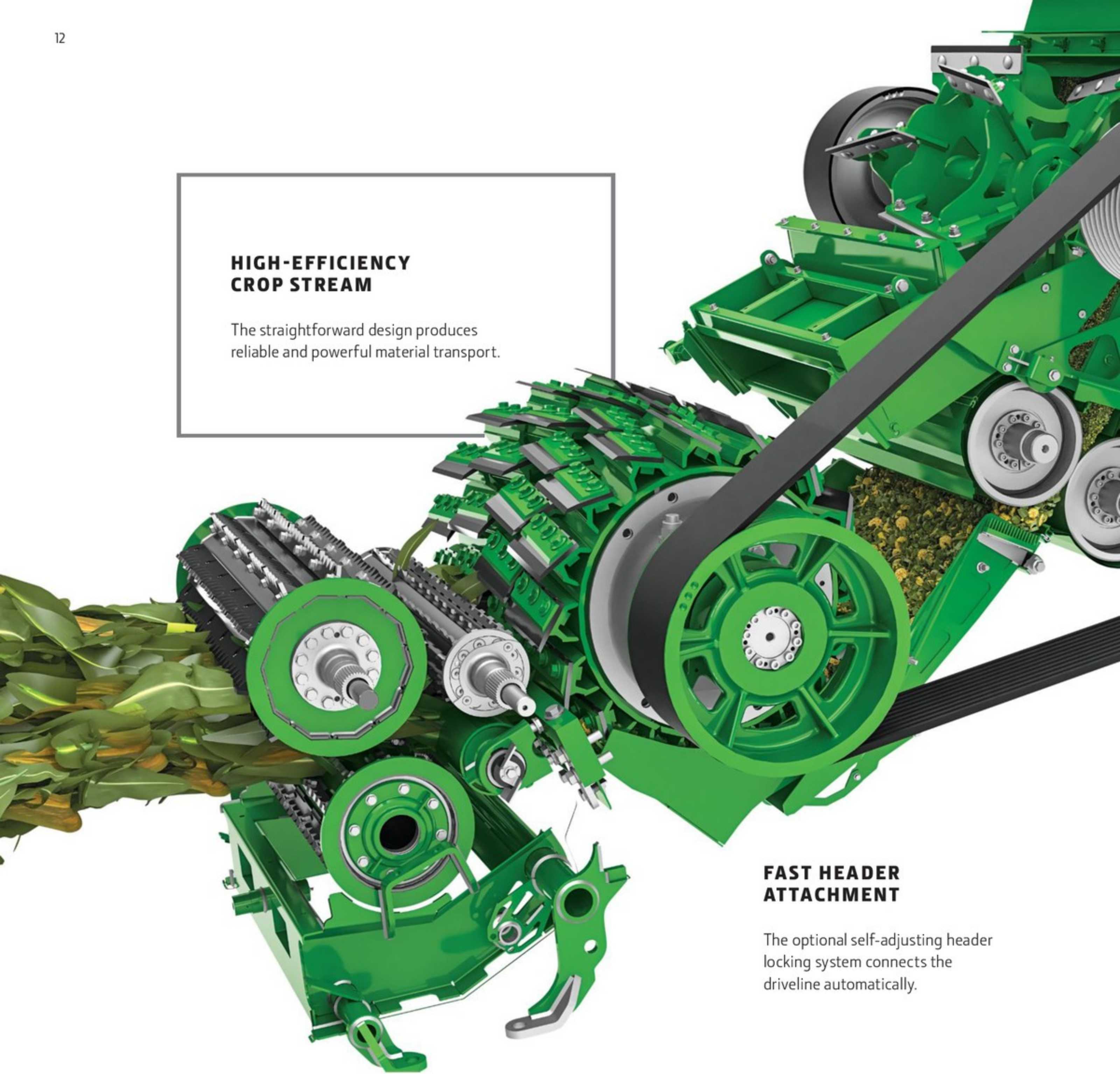



# PROSTREAM: HIGH POWER, LOW FRICTION

## CROP FLOW

The ProStream crop flow is designed with extra heavy-duty components for even higher engine horsepower outputs and a throughput capacity of more than 400 tons per hour. The smooth, gentle arc of the channel minimizes resistance for an even crop flow stream and lower wear.

### LONG-LASTING HYDRAULIC KNIFE SHARPENER

The new all-hydraulic system is more resistant to vibrations for better reliability.

### REVERSE-MODE KNIFE SHARPENING

This exclusive feature results in exceptionally low power requirements for cutting and crop transition.

### FEEDROLL ADVANTAGE

Four feedrolls, perfectly synchronized with the header, produce a smooth cropflow; springs ensure a flat crop mat for perfect cutting quality.

### EXTRA-FINE SHEARBAR ADJUSTMENT

The adjustment pivoting point is positioned far below the shearbar, ensuring minimum horizontal change when adjusting worn knives.

### 5-MINUTE KERNEL PROCESSOR CHANGEOVER

Its swing-out/swing-in design allows it to be moved out of the crop flow and to be replaced with a grass chute in minutes, not hours.

### HIGH-QUALITY, HEAVY-DUTY BEARINGS

The extra-strong bearings are designed for loads and throughput much higher than they'll ever have to bear.

# ONE CUTTERHEAD, ALL CROPS.

## CUTTERHEAD

Our universal cutterhead is designed to perform with remarkable flexibility for potentially very different harvesting requirements.

It will meet your demands without having to compromise forage quality. Depending on your specific requirements, you can also choose from 40-, 48- and 56-knife configurations.

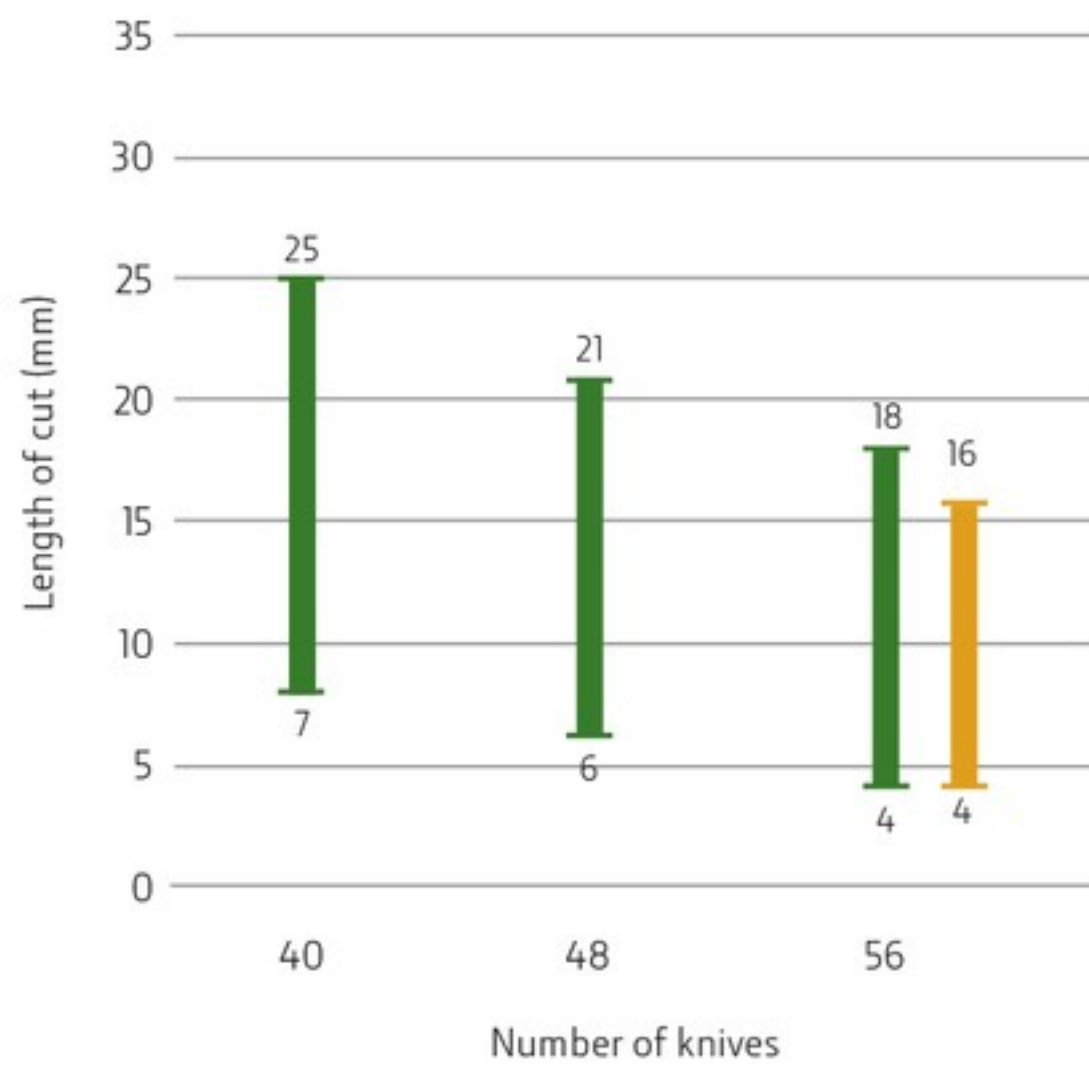
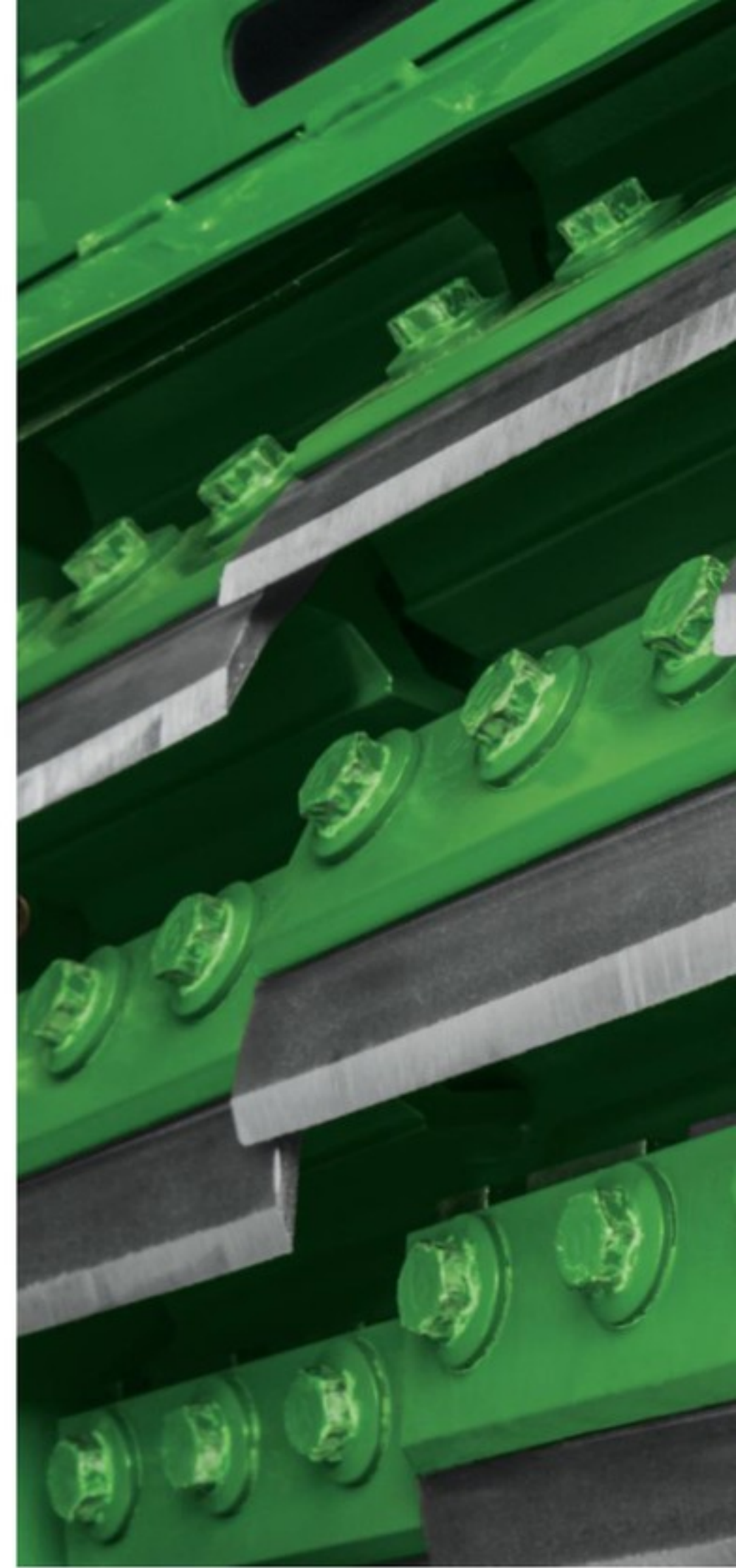

The Dura-Drum cutterhead design offers a wide length-of-cut range.

Length of cut for 9700-9900 models  
 ■ @ cutterhead speed of 1,170 rpm  
 ■ @ cutterhead speed of 1,350 rpm  
 For 9600 model, please see technical specifications (p. 46)

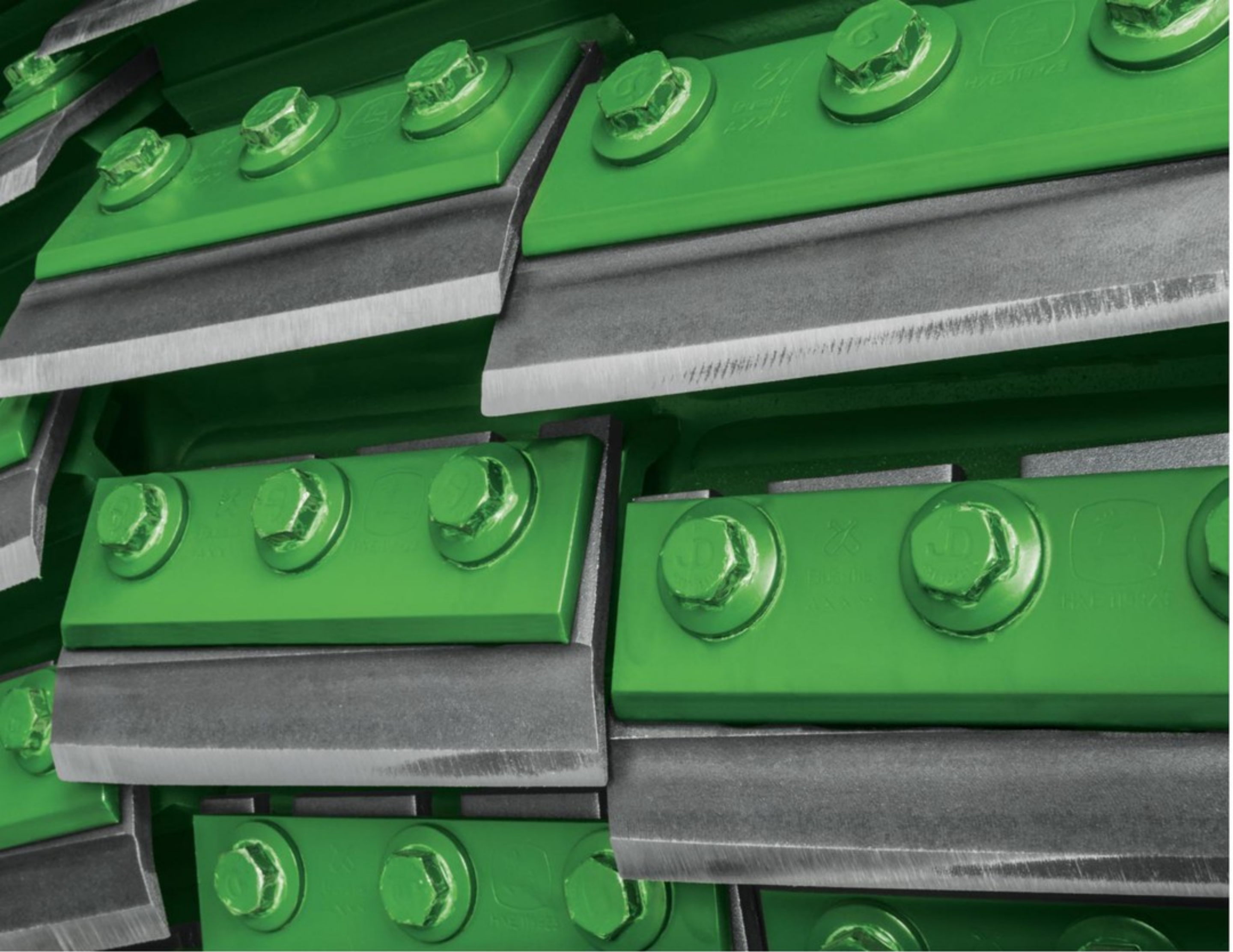

### **SMOOTH CROP FLOW**

Using advanced high-speed video cameras, we were able to understand and refine the crop flow in ways that were simply not possible a few years ago. The large-diameter 26.8 in. (680 mm) drum creates a faster crop flow, which makes a big difference when the harvester is working at extra-short cut lengths. The net result is higher throughput with lower power consumption.

### **HIGH-EFFICIENCY CUTTING**

The combination of the knife holder design and long knives, with a 0.8 in. (20 mm) tungsten carbide coating, means you can keep chopping without any loss in performance as the knives wear. What's more, with our smart shearbar system, it's never been easier to cut high-quality silage all season long.

### **LOWER FUEL CONSUMPTION**

The unique design of the knife holders creates a more uniform and bundled crop stream. They also optimize the point of exit for the crop, helping to reduce the overall power demand of the crop flow. When you're chopping nonstop, day after day, that adds up to significant fuel savings.

### **MAXIMIZE LIVESTOCK POTENTIAL**

Our cutterhead design gives you much more chopping flexibility. You can use the 40-, 48- and 56-knife cutterheads with 1/2 or 3/4 knife configurations for even longer lengths of cut in grass. Totally unique to John Deere, it means you can meet all the needs of livestock and dairy farmers with a single cutterhead.

# QUALITY SILAGE

## KERNEL PROCESSING

The massive throughput of the 9000 Series creates special demands for kernel processing – our XStream™ KP and Premium KP™ handle them with ease.

### XSTREAM KP

Together with the renowned experts from Scherer, Inc., a global leader in kernel processing roll design, we developed the new John Deere XStream kernel processor for these high-horsepower models. With 10 in. (250 mm) diameter rolls and 50% speed differential, it delivers consistently smashed kernels and intensively processed plants regardless of chop length.



Dura Line sawtooth and Dura Line XCut kernel processing rolls



### PREMIUM KP

Our Premium KP is a proven high-intensity processing solution that produces excellent forage quality at any length of chop and features Dura Line rolls for longer equipment life with more volume.



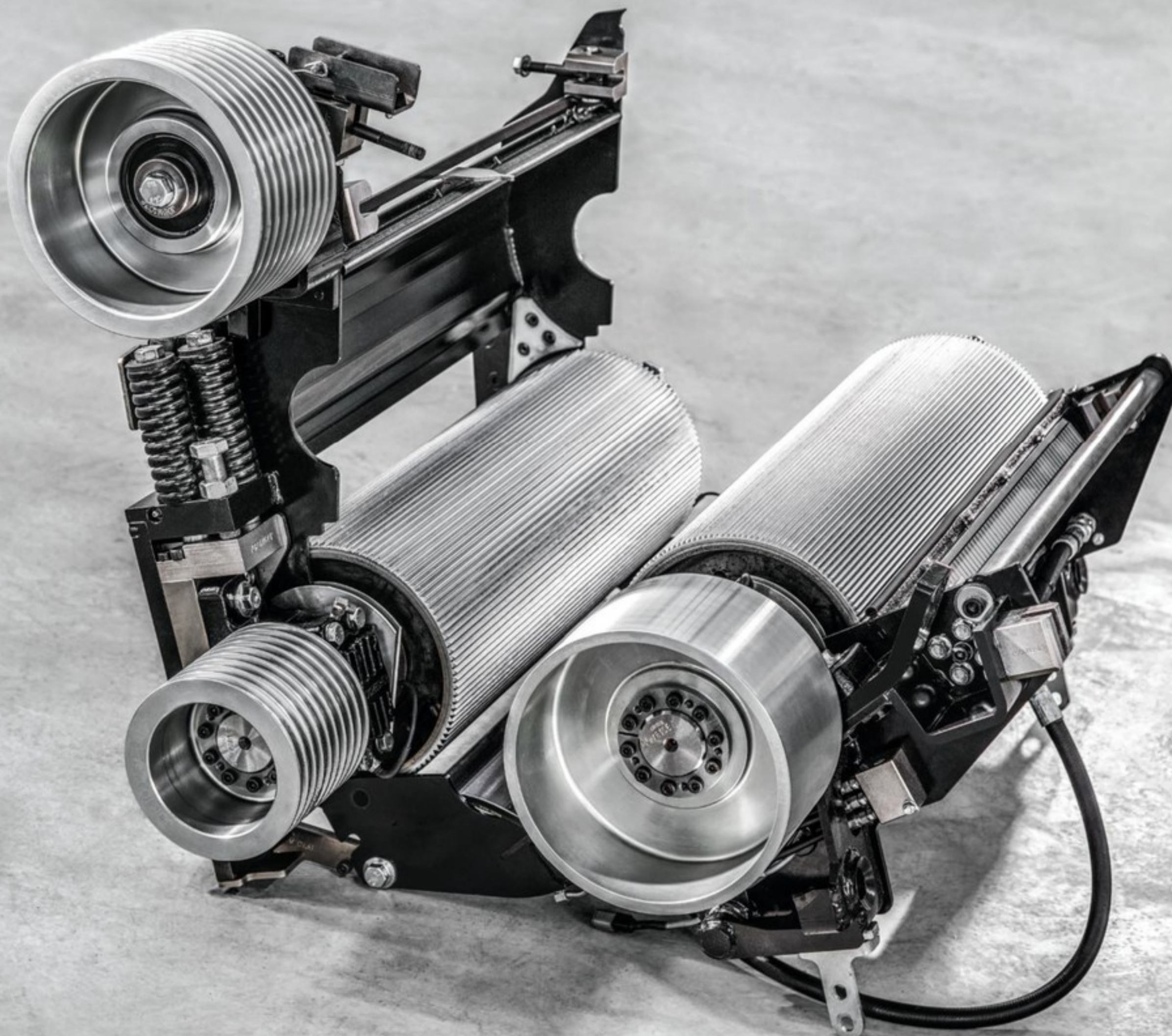

Up your processing productivity and consistently achieve smashed kernels and intensively processed plants with the new John Deere XStream kernel processor – shown here with Dura Line sawtooth rolls.

	PREMIUM KP	XSTREAM KP
<b>BASE FEATURES</b>		
Housing	Standard KP housing	Heavy-duty housing with KP roll quick exchange system
Lubrication	Grease lubrication	Pressurized oil lubrication
Roll diameter	9.4 in. (240 mm)	10 in. (250 mm)
Speed differential	32%	50%
<b>OPTIONS</b>		
40% speed differential	■	–
Bearing temp. monitoring system	–	■
<b>KP ROLLS</b>		
Standard Sawtooth	■	–
Dura Line Sawtooth	■	■
Dura Line XCut	–	■
Whole Crop	■	–
Whole Crop XCut	–	■

**PICK-UP 6X9**

MODEL	TRANSPORT WIDTH	WORKING WIDTH
639	9.8 ft (3 m)	8.4 ft (2.56 m)
649	13.1 ft (4 m)	11.94 ft (3.64 m)
659	14.8 ft (4.5 m)	13.62 ft (4.15 m)

**VARIABLE HEADER DRIVE**

If you've been looking to improve feeding at all lengths of cut, you'll be pleased with the variable pick-up speed feature of the 6X9. Both standard pick-up reel and auger speed are linked to the feedrolls of the SPFH to guarantee a constant crop flow and optimized throughput.



# ALL-STAR HEADER PERFORMANCE

## HEADERS

For the productivity levels you're looking for from the 9000 Series, only the most advanced headers will do. Our range is designed for radical efficiency and total reliability. We've also introduced self-centering attaching points, a single-lever locking mechanism and a multi-coupler for all hydraulic and electrical connections. And finally, "header recognition" does away with recalibration after header changes.



## GRASS: NOTHING LEFT BEHIND

For the 9000 Series, we offer our 6X9 premium pickups, which are designed especially for high-horsepower grass collection. Wherever the job, whatever the conditions, the new premium parts stay in the game longer in extreme field conditions – because it's Dura Line. Not only is the pickup reel stronger, we also added heavy-duty chains. The robust auger with extra wear strips and deck plates with extra Dura Line coating on the corners will last at least 3 times longer.

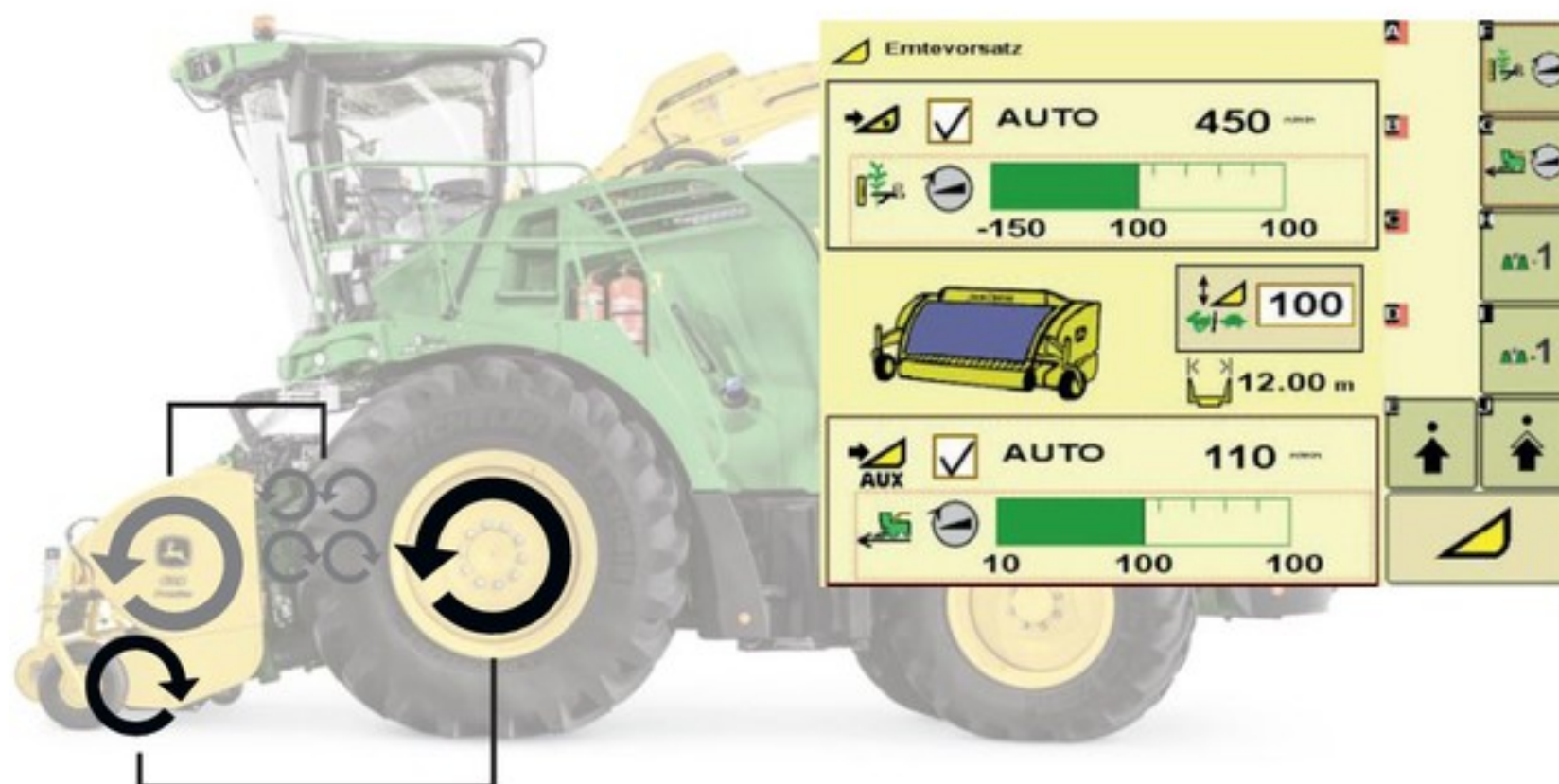

## EXTRA THOROUGH

Variable header drive (in base) synchronizes auger speed to LOC for great chopping quality. No matter if harvesting lighter or very heavy windrows, the optional dual header drive adjusts the speed of the pickup tines independent of the auger, matching the ground speed. No crop gets left behind.



PROFI CUT	
MODEL	WORKING WIDTH
530	17.4 ft (5.3 m)
700	23 ft (7 m)

## DESIGNED FOR PEAK PERFORMANCE

Built for John Deere, Zürn ProfiCut 530 and 700 are high-efficiency headers developed for cutting whole-crop silage clean and low with a tried-and-true disc cutterbar. To help you achieve maximum throughput with optimal forage quality, you're even able to adjust the auger speed to the length of cut.



# WHOLE-CROP SILAGE PERFORMANCE

When you focus, you get superior results. Zürn is a John Deere partner that specializes in producing high-end attachments for harvesting machinery. For whole-crop silage harvesting, it doesn't get any better than the ProfiCut headers from Zürn.

## BIG VOLUME

Large floating auger for superior intake performance of very large yield quantities.

## PERFECT FIT

Ideal for the wide body of the 9000 Series and quick header adaptation.

## LUBED FOR LIFE

The disc cutterbar is maintenance-free for continuous precision cutting quality and clean stubble.

## LESS DOWNTIME

The quick-knife-replacement system keeps such interruptions short.

## CROP VERSATILITY

Easily mounted side knives feature fast coupling and collision protection – switch to new crops fast and easy.

## MORE RELIABILITY

The powerful outer drives of the two separate cutterbars are synchronized for reliable operation and superior longevity.

## HIGH CROPS

The hydraulically adjustable front deflector lets you adjust the header to very high crop from the driver's seat.

## AUTO CHAIN LUBE

No need to worry about chain lubrication – it happens automatically.

## LOADING CONVENIENCE

Loading and unloading is a breeze with the hydraulically lowered header transporter.





### **HIGH-SPEED CUTTING**

Fast-turning rotors offer a perfect cut even under the most difficult conditions, such as wet crops with lots of weeds.

### **HEADER VERSATILITY**

Chop corn and many other crops for feed or biogas production even under tough conditions and cut covering the full working width.

### **LESS WEAR**

Power is transmitted by closed oil bath gearboxes and slip clutches for minimal wear at the driveline parts.

### **LUBE FASTER**

Our headers feature fewer lubrication points to make daily maintenance easier and quicker.

### **INSPECT LESS**

The main hexagonal shaft in our headers connects all gearboxes and minimizes daily inspection requirements.



# FLEXIBLE, LEGENDARY RELIABILITY

Built by Kemper, a John Deere company, our 600 and 700 Series Corn Headers are renowned worldwide for high capacity, reliability and low maintenance. With the wide variety of header sizes, you can choose what fits best for you.



## TRANSPORT: QUICK AND CONVENIENT

We've made transport efficiency a priority so you don't lose any time when changing fields.

The double-fold mechanism of the new 12-row 772 Head allows you to fold the entire head in approximately 30 seconds on the go. When others are still folding, you'll already be chopping!

## PICK UP DOWN CROP

The integrated low outer pointers make sure down crop gets picked up perfectly every time.

## FAST STUBBLE DECOMP

Specially shaped cleaners on the underside of the cutting rotors break up sharp-edged corn stubble for faster decomposition and less tire damage.

## QUICK FIELD CHANGES

Optional ProTouch and fast-folding headers make changing fields fast and easy.

## STEERING SENSOR

It allows you to direct your full attention to the header and spout functions for increased productivity.

## ADVANCED CONTROL

The perfect header position every time, thanks to the active height control of Advanced Header Control (AHC).

## ATTACH IT FASTER

The multi-coupler and the optional integrated quick coupler make attachment and removal a fast and painless process.



# COMPACT PERFORMER

## 600 SERIES HEADERS

Short, compact and with a lightweight small-drum design, the 600 Series is easy on the soil and great for short to medium-height crops.

For the 9000 Series, the 600 Series is available in 8-, 10- and 12-row 30-in. working widths, which gives you a perfect fit for what you're harvesting most. The row-independent harvesting technology lets you work the field from any side. Thanks to the even lengthwise feeding, the 600 Series is your best choice for perfect chopping quality.



### SUPERIOR COVERAGE

Row-independent harvesting technology with fast-running rotors for seamless cutting over the entire width.

### SHORT AND COMPACT

The compact design gives you a better view for enhanced road transport.

### IT'S LIGHTER

We've reduced the overall weight so there's less of it on the front axle. You'll leave the field in better shape with less soil compaction.

### WIDE RANGE

The 600 Series features a wide range of working widths. Choose from 8-, 10- or 12-row 30-in. working widths.





**ROTARY HEADER 600 SERIES**

MODEL	WORKING WIDTH	TRANSPORT WIDTH	30-IN. ROWS
698	19.7 ft (6 m)	9.8 ft (3 m)	8
690	24.6 ft (7.5 m)	9.8 ft (3 m)	10
692	29.5 ft (9 m)	10.8 ft (3.3 m)	12

**MOUNTING COMPATIBILITY**

MODEL	9600	9700	9800	9900
698	■	□	□	□
690	■	■	□	□
692	□	■	■	■

■ Recommended

□ Possible

# THROUGHPUT CHAMPION

## 700 SERIES HEADERS

When you need to harvest lots of high-yield crops fast, you can count on our 700 Series.

Designed and built for the greatest throughput, the 700 Series uses the big drum design to cut, gather and feed the crop into your SPFH. Developed with an emphasis on customer value, the 700 Series machines shine when you're looking for more yield, more productivity and more performance under extreme conditions.



ROTARY HEADER 700 SERIES			
MODEL	WORKING WIDTH	TRANSPORT WIDTH	30-IN. ROWS
778	19.7 ft (6 m)	9.8 ft (3 m)	8
770	24.6 ft (7.5 m)	10.8 ft (3.3 m)*	10
772	29.5 ft (9 m)	9.8 ft (3 m)	12

\*All dimensions are nominal dimensions. Actual dimensions may vary from case to case.

MOUNTING COMPATIBILITY				
MODEL	9600	9700	9800	9900
778	■	□	□	□
770	■	■	■	■
772	□	■	■	■

■ Recommended      □ Possible



### **ALL NEW 772**

Maximum performance and highest throughput in even the toughest conditions.

### **HIGH-YIELD EXPERT**

The 700 Series is designed for harvesting high-yield crops even under very difficult harvesting conditions.

### **LESS BLOCKAGE**

The design has fewer handover points, which lowers blockage risk and creates a more direct crop flow for higher throughput.

### **PRIME QUALITY**

The plants go fully lengthwise through the header to the feed rolls to achieve a perfect chopping result.

### **FULLEST REACH**

Get more done faster with the new 12-row large drum header of the 772 and its six equally sized drums.

### **MOVE IT FAST**

The double-fold mechanism of the 772 folds the entire header in about half a minute on the go – and it's on to the next field.

# FULL TRACTION, FULL CONTROL

## TIRES & PRODRIVE™

John Deere forage harvesters deliver enormous traction and superior control in all driving conditions – you profit from bigger tires and ProDrive as standard features.

### BIGGER TIRES, BETTER GRIP

With diameters up to 84.6 in. (2.15 m), the 9000 Series features extra-big tires. It also offers up to a phenomenal 20 inches (0.5 m) of ground clearance. And with tire pressure as low as 14.5 PSI, you have a simple and efficient formula that gives you more traction and less compaction, while still allowing you to zip along at speeds of up to 25 mph (40 km/h) on the road.





## PRODRIVE – A TRANSMISSION BENCHMARK

ProDrive is the other half of the traction equation, with numerous added benefits. The sophistication of this breakthrough transmission technology stays on the inside – to you, it is supremely easy to operate. ProDrive provides automatic shifting across two pre-set speed ranges in which you select a speed that will be maintained continuously, even when you're harvesting downhill on slopes. It could not be simpler: There's no gear lever and no parking brake, just a master control lever you push to move. Braking is just as easy – just pull back the lever and two brake units, and the parking brake engages automatically. While ProDrive gives you all the traction you need, it is also gentle on soft soil. On a 4WD harvester, if a wheel loses traction, the hydraulic flow is automatically directed to the wheels that still have grip and you keep moving. On softer soil, a speed differential between the front and rear axles prevents the wheels from disturbing the soil when turning.



**HIGHEST GROUND CLEARANCE AVAILABLE ON THE MARKET**



## SIT BACK AND RELAX

### CAB

It's quiet in here. You can focus and relax. You have all your comforts and tech tools at hand to enjoy acre after acre of pure productivity. Sit back and smile – you're in a 9000.

### SEE MORE CLEARLY

More glass, fewer obstructions, less reflection, rain or shine, day or night. It's all about a better view of everything.

### ERGONOMIC CONTROLS

Perfectly laid out controls with lots of programmable keys on the CommandARM™, which moves with the seat.

### ONE-HANDED CONTROL

All key controls, one multi-function lever: speed, header fold and lift, spout turn and lift, feedroll and header engagement.



**ON TOP OF THINGS**

The higher driving position gives you more control. The center-cab seat adjusts and features air suspension for operator comfort.

**INSTRUCTOR SEAT**

Enough room for a passenger or second driver. When not needed, the seat folds away and turns into a work space.

**CONTROL YOUR CLIMATE**

Precisely adjust your air conditioning from the CommandARM™.

**ONE GLANCE, TOTAL INFORMATION**

All essential operational data is displayed with extra-sharp text and graphics for quick and effortless reading.

**STORAGE APLENTY**

Lots of space available to store anything you need to bring along, plus an optional refrigerated compartment.

**CHARGE AND CONNECT**

Lots of 12V sockets for charging mobile devices, plus Bluetooth® to connect to the audio system for calls or music.

**MAINTENANCE EASE**

Enjoy the convenience of an automatic oil and greasing system that allows you to lubricate the pick-up from the cab.



**A COMMANDING VIEW**

Bluetooth is a registered trademark of Bluetooth SIG, Inc.



Thanks to their unique hard-wearing high-tech coating, Dura Line parts help significantly reduce in-season downtime.

25 mph (40 km/h)  
speed limit depending  
on country.



## SAVING FUEL ON THE ROAD

Getting an SPFH from field to field on the road is not exactly its most productive time and costs you fuel and money. That's where John Deere engine speed management comes in. It reduces engine rpm during road transport while you maintain a productive ground speed – more fuel efficiency, more savings.





## GOOD FOR BUSINESS

The more resources you have available to you, the more you can accomplish, the more you can evolve. That's why everything about the new 9000 Series was designed to help you cut down your cost of operation.

### COMPONENTS THAT LAST

In the end, it's about money – when the wear parts of your machine last longer, the machine becomes more profitable. That's why we packed the 9000 Series chock full of ultra-hard-wearing Dura Line components throughout the crop flow – shearbars, knife holders, the chute – Dura Line is everywhere to let you go season after season without exchanging wear components.

### STRETCHED-OUT SERVICE INTERVALS

Oils and filters in the Liebherr engines and the hydraulic system need to be changed regularly – that's time and money. But in our case, less of that. Change engine oil and filters only every 1,000 hours – up to 2,000 hours for hydraulic oil and 1,000 for hydraulic filters.



# READY TO HELP

## SERVICES

Your 9000 Series SPFH comes with a dealer network that is there for you 100% – with answers, parts and services that will make sure that you get the very best from your machine.



## BUY WITH CONFIDENCE

You can purchase a new John Deere SPFH with more peace of mind than ever. PowerGard™ plans offer valuable extended warranty\* coverage to protect you from unforeseen future repair bills and potentially costly downtime. Trust your machine will be repaired by the experts at your John Deere dealership using only Genuine John Deere Parts. And with flexible coverage options, you can choose the terms that fit your needs. If your ownership plans change, any remaining PowerGard coverage is fully transferrable.



\*PowerGard Protection Plan extended warranty covers failures due to defective materials or original workmanship of covered components. Customers have a choice between either the Limited (engine & powertrain) coverage form or the Comprehensive (full-machine) coverage form. See your dealer, [www.JohnDeere.com/PowerGard](http://www.JohnDeere.com/PowerGard) or [www.JohnDeere.ca/PowerGard](http://www.JohnDeere.ca/PowerGard) for details.



## WE'LL KEEP YOU MOVING

When you need a part, you need it fast. Your dealer keeps most of them in stock. For everything else, the professional John Deere logistics network brings it in promptly. You can count on it.



## CONNECTED SUPPORT

John Deere Connected Support™ is a suite of telematics systems that enables your dealer to better support you. With a JDLink™ connected machine, you can check in on work in progress. You can also grant your dealer access to monitor machine alerts, diagnose problems and push software updates remotely. The technology behind these systems is advanced, but the benefits are simple – John Deere Connected Support saves you time and money.



# FAST AND FLAWLESS

## AUTOTRAC™ & ROWSENSE™

Automatic hands-free guidance is an essential feature for high-volume harvesting operations when you need to fully load the harvester hour after hour.

Apart from ensuring you get a full header width with every pass, it saves fuel by eliminating missed or skipped sections and lets you consistently harvest at higher speeds hour after hour. Guidance also has the added benefit of taking away the stress of harvesting tall corn and other row crops. So you can relax and focus on other essential tasks and processes for cutting excellent silage.

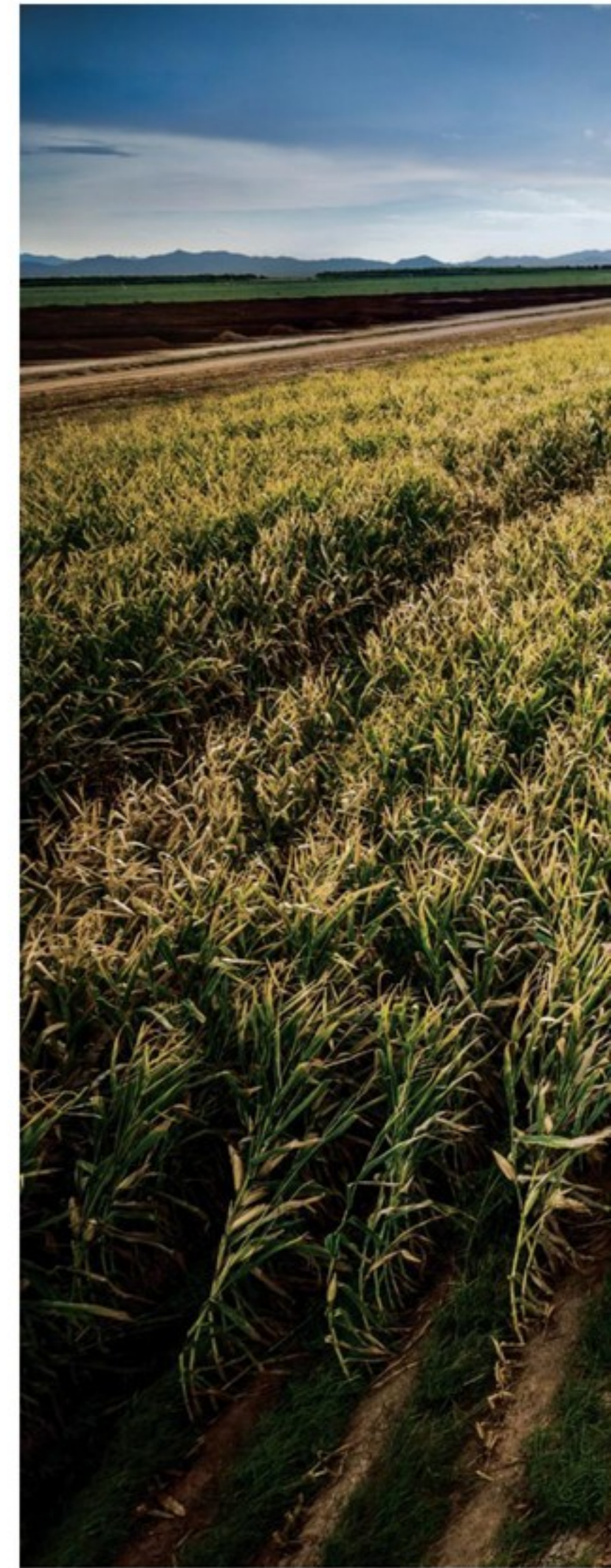

## MANUAL ROWSENSE

Exclusively designed for harvesting corn, Manual RowSense is an electro-mechanical system that uses digital feelers mounted in the corn header to follow the position of the stalks. The signal from the feelers is relayed to a wheel angle sensor and the wheels are automatically adjusted to align the harvester precisely in line with the crop. It is very flexible and will work in row spaces from 20 to 33 inches (50.8 to 83.82 cm). Using Manual RowSense couldn't be simpler. Operated via a single button on the multi-function control lever, it automatically compensates for any uneven planting or field contours. The steering is adapted to the ground speed of the harvester and becomes more responsive as the machine's speed increases.





## RELAX, FILL, REPEAT – ACTIVE FILL CONTROL

John Deere Active Fill Control utilizes a stereo camera to control the rotation and flap position of the spout automatically. The system can actively track transport vehicles and aim the crop from the best position to execute a desired fill strategy, including in rear-unload conditions when opening up a new field.\* Meanwhile, you can relax and bring your focus to overall harvesting optimization and machine operation.

\*Requires StarFire™ receiver.

# BETTER INFORMATION, MORE VALUE

## HARVESTLAB 3000 FORAGE AND MANURE ANALYSIS

Take real-time forage and manure information from the HarvestLab 3000 sensor and make in-field adjustments to create the best product you have ever delivered – on the fly, accurately and reliably.

### ONE SENSOR, THREE APPLICATIONS

A true multi-purpose device, you can use HarvestLab 3000 on an SPFH, a slurry tanker or as a mobile laboratory.

Fitting HarvestLab 3000 to a slurry tanker lets you precisely apply N/P/K in kg/ha, save on mineral fertilizer, and achieve better and more consistent crop growth and quality.

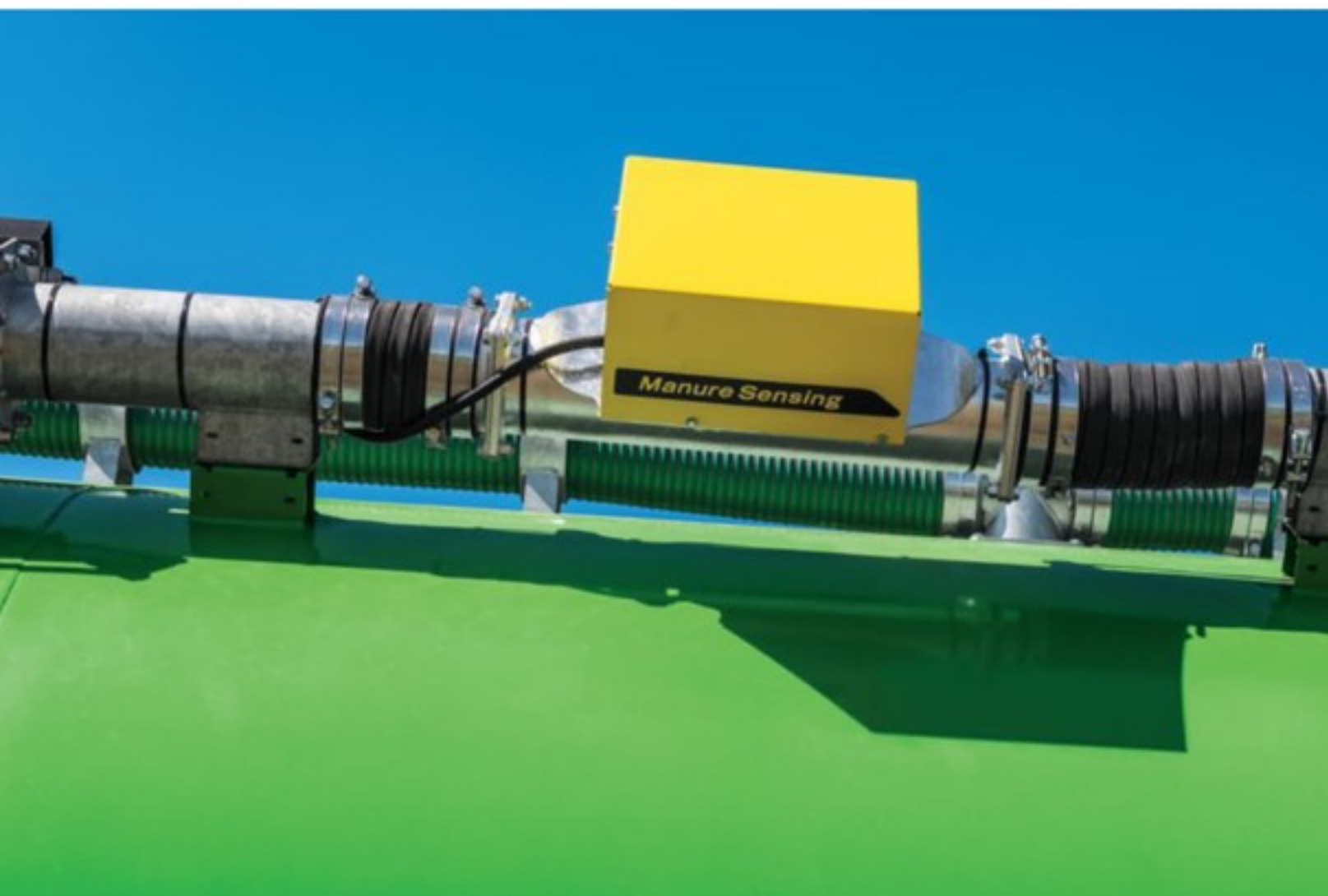

HarvestLab 3000 also pays off after manure or forage harvesting season: Take it off the machine to use the sensor as a stationary unit that measures the ingredients of your ensiled material from the clamp in order to optimize your feed rations.





	SPFH	MOBILE LABORATORY	SLURRY TANKER
HarvestLab 3000 Sensor	■	■	■
Constituent Sensing Calibrations	■	■	-
Turn Table & Stationary Kit	-	■	-
StarFire Receiver	■	-	■
4640 Display or GreenStar 3 2630 Display	■	-	■
Manure Sensing Calibrations	-	-	■
Manure Sensing Kit	-	-	■

# THE SECRET TO GREAT SILAGE

## HARVESTLAB 3000 ON YOUR SPFH

HarvestLab 3000 simultaneously measures the dry matter and various constituents of harvested crops. Its sensor uses near-infrared-reflectance (NIR) technology that takes over 4,000 readings per second to produce instant and highly accurate data on the go. The technology has been certified by the Deutsche Landwirtschafts-Gesellschaft (DLG) for dry-matter analysis of corn silage with a +/- 2% precision. Since its introduction in 2008, thousands of HarvestLab units have been operating around the world, with excellent performance even in challenging field conditions.

Fitted to an SPFH, HarvestLab 3000 enables automated length of cut adjustment depending on dry-matter content, ensuring optimum silage compaction and conservation. Additionally, livestock and dairy farmers profit from real-time detection of changes in feed quality and better control over the use of silage additives. Biogas producers like HarvestLab 3000 because it gives them accurate information on the actual crop quality they buy.



CROP TYPE	DRY MATTER (DM)	CRUDE PROTEIN (XP)	STARCH	CRUDE FIBER (XF)	NDF (OM)	ADF (OM)	SUGAR (XZ)	CRUDE ASH
Corn	■	■	■	—	■	■	—	—
Grass	■	■	—	■	■	■	■	■
Alfalfa	■	—	—	—	—	—	—	—
Whole Crop Silage	■	—	—	—	—	—	—	—



### CAPABILITIES AT ONE GLANCE

- DM, protein, starch, fiber, NDF, ADF, Crude Ash and sugar analysis on-the-go
- Automatic length-of-cut adjustment
- Precise dosing of silage additives





Easy to read display

## INTEGRATED CROP DOSING

HarvestLab sensor readings also work beautifully with another feature of the 8000 and 9000 Series – the fully integrated ADS Twin Line system doses silage additives based on time, harvested tons or on dry-matter tons using HarvestLab sensor readings. Supplied from two different tanks, the dosing nozzles are positioned at air intake of the crop accelerator and allow you to choose either fixed or variable dosing rates based on moisture readings from HarvestLab. The twin tanks allow you to add two different inoculants together, or apply them at different times, giving you the flexibility to adapt to each specific job's needs.

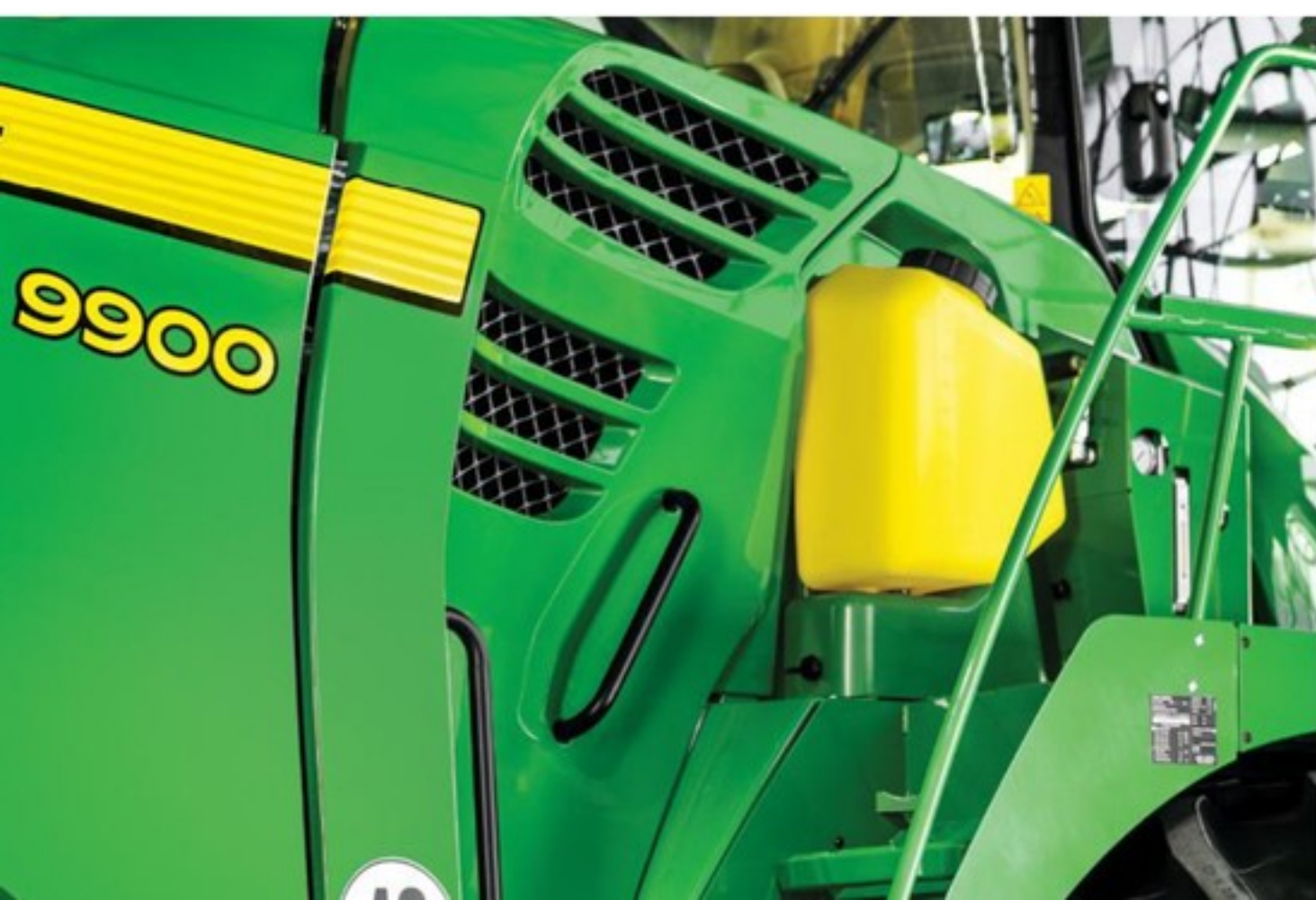

8-gallon concentrate tank

# MOBILE INTELLIGENCE

THE EVERYWHERE LAB



The John Deere HarvestLab 3000 sensor can also be used as a laboratory unit at a storage facility or home office. Connecting to a vehicle power outlet keeps you completely mobile and provides you with instant information wherever you are.



Daily analysis is critical to ensure proper bunk management, feed rationing and livestock health. As a result, you can save on unnecessary supplements while achieving higher yields in beef, dairy or biogas production and ultimately higher business profitability.



## BE SMART ABOUT YOUR MANURE

### HARVESTLAB 3000 ON A SLURRY TANKER

HarvestLab 3000 is manure technology with real bottom-line impact. Enjoy instant, accurate, on-the-go nutrient analysis with over 4,000 readings per second with comprehensive automated site-specific application and nutrient documentation. In the end, you're using less mineral fertilizer while achieving higher yields. Of course, it's fully compatible with manure systems from Fliegl, Joskin, Kotte, Pichon, Samson and Vervaet, and you can also retrofit it to drag hose systems independent of brand.



1. Site-specific Application – John Deere Manure Sensing is controlled intuitively via the familiar Generation 4 or GS3 2630 display. Prior to application, you define the target rate for one nutrient. You can then define a limit rate for a second nutrient. For an even higher level of precision, you can upload site-specific prescription maps.

2. The NIR sensor constantly compares actual nutrient levels with target levels and automatically controls the speed and/or flow regulation to ensure the desired nutrient rate is applied. In case a given speed limit is reached, flow rates can be adjusted for selected slurry tanker brands.

3. Documentation – Up to 4 nutrients can be documented site-specifically and sent to the John Deere Operations Center. Based on this information, prescription maps for secondary mineral fertilizer application can be derived and sent back to the machine. This saves you mineral fertilizer costs and optimizes the nutrient supply for your crops.

MANURE TYPE	DRY MATTER (DM)	N <sub>TOT</sub>	P (P <sub>2</sub> O <sub>5</sub> )	K(K <sub>2</sub> O)	NH <sub>4</sub>
Pig	■	■	■	■	■
Cattle	■	■	■	■	■
Biogas Digestate	■	■	■	■	■





## YOUR GATEWAY TO BETTER BUSINESS DECISIONS

You're managing a complex enterprise. That's why optimizing the overall business depends on being well connected to your ongoing operations.

The Operations Center on our Ag web portal, MyJohnDeere.com, makes it simple. It connects you to your machines, your operators and your fields from one central location. It also allows you to exchange information seamlessly with your John Deere dealer or other trusted partners.

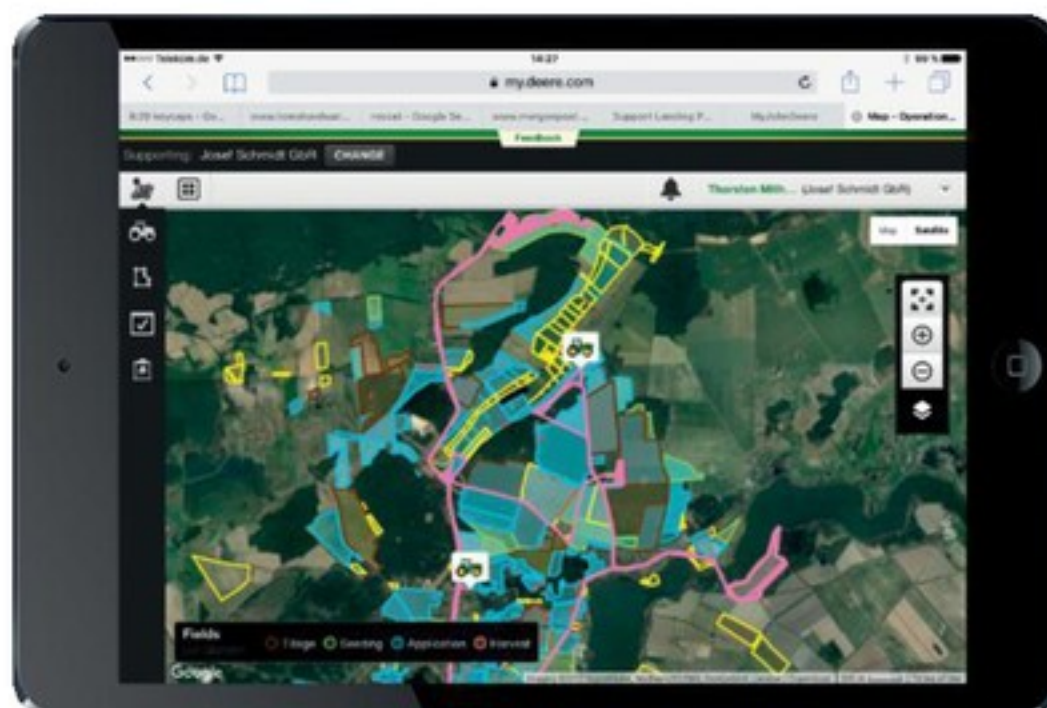

John Deere Operations Center – Allocate exact field locations for the next jobs, track the work progress of your machines, assign work orders to your operators, view “as-applied” maps automatically sent from the field, and create, analyze and share application reports with partners and customers.

## SPECIFICATIONS

MODEL	9600
<b>ENGINE POWER</b>	
Maximum power @ 1,800 rpm ECE R120, Pferdestärke (hp, kW)	625 PS (616 hp, 460 kW)
Fuel tank capacity	290.6 gal (1,100 L)
DEF tank capacity	11.4 gal (43 L)
<b>ENGINE</b>	
Manufacturer	John Deere
Type	PowerTech PSS 13.5L Exhaust emission regulation compliancy: Tier 4 Final / Stage V
Model	6135HZ021
Displacement	13.5 L
Cylinders	In line six
Fuel system	Unit injectors plus four valves
Air compressor	Optional
<b>COOLING SYSTEM</b>	
Cooling system capacity	29.8 gal (113 L)
Cooling fan drive	Direct
<b>DRIVELINE</b>	
Ground drive	Prodrive, autoshift transmission, differential lock (automatic and manual), automatic wet brake system Engine rpm on road: 1,400-2,100 rpm
Main Hydraulics	Load sensing
Main clutch	Dry clutch
Number of clutch discs	One disc
Main driveband	Reinforced with Kevlar inserts
Belt tensioning	Active, hydraulic pressure
Main driveband, polybelt belts	Six grooves
<b>ELECTRICAL SYSTEM/ELECTRICAL AND HYDRAULIC SYSTEM</b>	
Type/voltage	12 V
Battery quantity/capacity	2 x 174 amp-hr
Alternator	200 amp
Hydraulic system capacity	13.2 gal (50 L)
<b>GROUND DRIVE</b>	
Maximum transport speed	12/16/19/25 mph (20/25/30/40 km/h)
Rear axle type	Hydro-Mechanical 4-WD
Automatic wet brake system	Standard
Engine rpm - Management	Standard
<b>LENGTH OF CUT</b>	
40 knives cutterhead	0.27-1 in. LOC in 0.04 in. steps / 1,100 rpm (7-26 mm LOC in 1 mm steps / 1,100 rpm)
48 knives cutterhead	0.24-0.87 in. LOC in 0.04 in. steps / 1,100 rpm (6-22 mm LOC in 1 mm steps / 1,100 rpm)
56 knives cutterhead	0.2-0.75 in. LOC in 0.04 in. steps / 1,100 rpm (5-19 mm LOC in 1 mm steps / 1,100 rpm) 0.16-0.67 in. LOC in 0.04 in. steps / 1,200 rpm (4-17 mm LOC in 1 mm steps / 1,200 rpm)
<b>HARVEST CHANNEL</b>	
Width	Wide body channel



9700	9800	9900
770 PS (759 hp, 566 kW)	870 PS (858 hp, 640 kW)	970 PS (956 hp, 713 kW)
396.3 gal (1,500 L)	396.3 gal (1,500 L)	396.3 gal (1,500 L)
23.8 gal (90 L)	23.8 gal (90 L)	23.8 gal (90 L)
Liebherr	Liebherr	Liebherr
D9512 A7 04	D9512 A7 04	D9512 A7 04
Exhaust emission regulation compliancy: Tier 4 Final / Stage V	Exhaust emission regulation compliancy: Tier 4 Final / Stage V	Exhaust emission regulation compliancy: Tier 4 Final / Stage V
D9512 A7 04	D9512 A7 04	D9512 A7 04
24.2 L	24.2 L	24.2 L
V 12	V 12	V 12
Common rail plus four valves	Common rail plus four valves	Common rail plus four valves
Standard	Standard	Standard
34.3 gal (130 L)	34.3 gal (130 L)	34.3 gal (130 L)
Direct	Direct	Direct
Prodrive, autoshift transmission, differential lock (automatic and manual), automatic wet brake system	Prodrive, autoshift transmission, differential lock (automatic and manual), automatic wet brake system	Prodrive, autoshift transmission, differential lock (automatic and manual), automatic wet brake system
Engine rpm on road: 1,200-1,800 rpm	Engine rpm on road: 1,200-1,800 rpm	Engine rpm on road: 1,200-1,800 rpm
Load sensing	Load sensing	Load sensing
Dry clutch	Dry clutch	Dry clutch
Two discs	Two discs	Two discs
Reinforced with Kevlar inserts	Reinforced with Kevlar inserts	Reinforced with Kevlar inserts
Active, hydraulic pressure	Active, hydraulic pressure	Active, hydraulic pressure
Eight grooves	Nine grooves	Nine grooves
12 V / 24 V	12 V / 24 V	12 V / 24 V
3 x 174 amp-hr	3 x 174 amp-hr	3 x 174 amp-hr
12 V - 200 amp / 24 V - 140 amp	12 V - 200 amp / 24 V - 140 amp	12 V - 200 amp / 24 V - 140 amp
13.2 gal (50 L)	13.2 gal (50 L)	13.2 gal (50 L)
12/16/19/25 mph (20/25/30/40 km/h)	12/16/19/25 mph (20/25/30/40 km/h)	12/16/19/25 mph (20/25/30/40 km/h)
Hydro-Mechanical 4-WD	Hydro-Mechanical 4-WD	Hydro-Mechanical 4-WD
Standard	Standard	Standard
Standard	Standard	Standard
0.27-1 in. LOC in 0.04 in. steps / 1,170 rpm (7-26 mm LOC in 1 mm steps / 1,170 rpm)	0.27-1 in. LOC in 0.04 in. steps / 1,170 rpm (7-26 mm LOC in 1 mm steps / 1,170 rpm)	0.27-1 in. LOC in 0.04 in. steps / 1,170 rpm (7-26 mm LOC in 1 mm steps / 1,170 rpm)
0.24-0.83 in. LOC in 0.04 in. steps / 1,170 rpm (6-21 mm LOC in 1 mm steps / 1,170 rpm)	0.24-0.83 in. LOC in 0.04 in. steps / 1,170 rpm (6-21 mm LOC in 1 mm steps / 1,170 rpm)	0.24-0.83 in. LOC in 0.04 in. steps / 1,170 rpm (6-21 mm LOC in 1 mm steps / 1,170 rpm)
0.16-0.71 in. LOC in 0.04 in. steps / 1,170 rpm (4-18 mm LOC in 1 mm steps / 1,170 rpm)	0.16-0.71 in. LOC in 0.04 in. steps / 1,170 rpm (4-18 mm LOC in 1 mm steps / 1,170 rpm)	0.16-0.71 in. LOC in 0.04 in. steps / 1,170 rpm (4-18 mm LOC in 1 mm steps / 1,170 rpm)
0.16-0.63 in. LOC in 0.04 in. steps / 1,350 rpm (4-16 mm LOC in 1 mm steps / 1,350 rpm)	0.16-0.63 in. LOC in 0.04 in. steps / 1,350 rpm (4-16 mm LOC in 1 mm steps / 1,350 rpm)	0.16-0.63 in. LOC in 0.04 in. steps / 1,350 rpm (4-16 mm LOC in 1 mm steps / 1,350 rpm)
Wide body channel	Wide body channel	Wide body channel

## SPECIFICATIONS

MODEL	9600
<b>FEEDROLLS</b>	
Feed roll frame opening	Swing away, 37-45° (angle)
Number feedrolls	Four
Metal detector	Standard
Stone detector	Optional
Feeding channel width, front	32.68 in (830 mm)
Hydro feedroll drive with Infinite Variable Length of Cut	Standard
<b>HEADER CONNECTION</b>	
Infinitely variable header drive	Standard
Lateral Pivoting frame	Standard
Mutli coupler	Standard
Auto PTO coupler	Optional
Header height and float pressure control	Standard
Hydraulic actuated lateral header tilt	Optional Advanced Header Control (AHC)
Grass pick-ups (transport width)	9.8, 13.1, 14.8 ft (3.0, 4.0, 4.5 m)
Corn headers	8, 10 or 12 rows
<b>CUTTERHEAD</b>	
Type	Dura-Drum cutterhead
Cutterhead width	33.46 in (850 mm)
Cutterhead diameter	26.38 in (670 mm)
Speed at rated engine speed	1,100 rpm / 1,200 (Option)
Number of knives	40 - 48 - 56
Knife types available (crop)	Straight (grass/universal) Curved (corn)
Shearbar options	Grass, Corn or Dura Line Plus
Fine Shearbar Adjust	Standard
Quick Shearbar Adjust	Standard
<b>KNIFE SHARPENING SYSTEM</b>	
Reverse rotation	Yes
Sharpening control	Remote from cab
Sharpening modes	Grinding and finishing
<b>KERNEL PROCESSOR</b>	
Available KP types	Premium KP, XStream KP
Quick KP removal	Crane with remote controlled electric hoist
<b>KERNEL PROCESSING OPTIONS</b>	
<b>PREMIUM KP</b>	
Housing	Standard KP housing
Lubrication	Grease
Roll diameter	9.45 in (240 mm)
Speed differential	32% (optional: 40%)
Corn, saw teeth number	118
Wholecrop, saw teeth number	178
<b>XSTREAM KP</b>	
Housing	Heavy Duty Housing
Lubrication	Pressurized oil
Roll diameter	9.84 in (250 mm)
Speed differential (%)	50
Corn, saw teeth number	110/145
Wholecrop, saw teeth number	145/165





9700	9800	9900
Swing away, 37-45° (angle)	Swing away, 37-45° (angle)	Swing away, 37-45° (angle)
Four	Four	Four
Standard	Standard	Standard
Optional	Optional	Optional
32.68 in (830 mm)	32.68 in (830 mm)	32.68 in (830 mm)
Standard	Standard	Standard
Standard	Standard	Standard
Standard	Standard	Standard
Optional	Optional	Optional
Standard	Standard	Standard
Optional Advanced Header Control (AHC)	Optional Advanced Header Control (AHC)	Optional Advanced Header Control (AHC)
9.8, 13.1, 14.8 ft (3.0, 4.0, 4.5 m)	9.8, 13.1, 14.8 ft (3.0, 4.0, 4.5 m)	9.8, 13.1, 14.8 ft (3.0, 4.0, 4.5 m)
8, 10 or 12 rows	8, 10 or 12 rows	8, 10 or 12 rows
Dura-Drum cutterhead	Dura-Drum cutterhead	Dura-Drum cutterhead
33.46 in (850 mm)	33.46 in (850 mm)	33.46 in (850 mm)
26.38 in (670 mm)	26.38 in (670 mm)	26.38 in (670 mm)
1,170 rpm / 1,350 (Option)	1,170 rpm / 1,350 (Option)	1,170 rpm / 1,350 (Option)
40 - 48 - 56	40 - 48 - 56	40 - 48 - 56
Straight (grass/universal)	Straight (grass/universal)	Straight (grass/universal)
Curved (corn)	Curved (corn)	Curved (corn)
Grass, Corn or Dura Line Plus	Grass, Corn or Dura Line Plus	Grass, Corn or Dura Line Plus
Standard	Standard	Standard
Standard	Standard	Standard
Yes	Yes	Yes
Remote from cab	Remote from cab	Remote from cab
Grinding and finishing	Grinding and finishing	Grinding and finishing
Premium KP, XStream KP	Premium KP, XStream KP	XStream KP
Crane with remote controlled electric hoist	Crane with remote controlled electric hoist	Crane with remote controlled electric hoist
Standard KP housing	Standard KP housing	—
Grease	Grease	—
9.45 in (240 mm)	9.45 in (240 mm)	—
32% (optional: 40%)	32% (optional: 40%)	—
118	118	—
178	178	—
Heavy Duty Housing	Heavy Duty Housing	Heavy Duty Housing
Pressurized oil	Pressurized oil	Pressurized oil
9.84 in (250 mm)	9.84 in (250 mm)	9.84 in (250 mm)
50	50	50
110/145	110/145	110/145
145/165	145/165	145/165

## SPECIFICATIONS

MODEL	9600
<b>CROP ACCELERATOR</b>	
Rotor Diameter / Width	22 / 24 in. (560 / 620 mm)
Number of blades	10
Rotor Speed [rpm]	1,800
<b>SPOUT</b>	
Rotation	210°
Reach from center line (ft) (optional) (ft)	15.5 ft (optional: 19.25 ft) 22 ft [4.73 m (optional: 5.87 m) 6.71 m]
Working height (maximum)	Height to spout: 21.7 ft (6.6 m)
Spout Camera	Optional
Active Fill Control	Optional
<b>CAB</b>	
Panoramic view windows	Standard
Touch screen display	Standard
Refrigerator	Optional
Bluetooth radio	Optional
<b>AGRICULTURAL MANAGEMENT SOLUTIONS</b>	
Yield monitoring	Harvest Monitor optional
Documentation	Harvest Doc optional
Crop analysis	HarvestLab 3000 optional
Length-of-cut control based on crop	AutoLOC optional with HarvestLab 3000
Assisted steering	AutoTrac or Manual RowSense optional
<b>VEHICLE</b>	
<b>FRONT TIRE OPTIONS</b>	
650/85 R38	Available
710/70 R42	Available
710/75 R42	Available
800/70 R38	Available
800/70 R42	Available
900/60 R38	Available
900/60 R42	Available
<b>REAR TIRES</b>	
500/85 R30	Available
520/85 R30	Available
620/70 R30	Available
620/75 R30	Available
650/60 R34	Available
710/60 R30	Available
750/65 R26	Available
Transport length (without header)	21.7 ft (6.6 m)
Transport width (without header)	10.2-11.5 ft (1.3-3.49 m)
Transport height (to cab roof)	Below 13.1 ft (4.0 m)



9700	9800	9900
22 / 24 in. (560 / 620 mm)	22 / 24 in. (560 / 620 mm)	22 / 24 in. (560 / 620 mm)
10	10	10
1,800	1,800	1,800
210°	210°	210°
15.5 ft (optional: 19.25 ft) 22 ft [4.73 m (optional: 5.87 m) 6.71 m]	15.5 ft (optional: 19.25 ft) 22 ft [4.73 m (optional: 5.87 m) 6.71 m]	15.5 ft (optional: 19.25 ft) 22 ft [4.73 m (optional: 5.87 m) 6.71 m]
Height to spout: 21.7 ft (6.6 m)	Height to spout: 21.7 ft (6.6 m)	Height to spout: 21.7 ft (6.6 m)
Optional	Optional	Optional
Optional	Optional	Optional
Standard	Standard	Standard
Standard	Standard	Standard
Optional	Optional	Optional
Optional	Optional	Optional
Harvest Monitor optional	Harvest Monitor optional	Harvest Monitor optional
Harvest Doc optional	Harvest Doc optional	Harvest Doc optional
HarvestLab 3000 optional	HarvestLab 3000 optional	HarvestLab 3000 optional
AutoLOC optional with HarvestLab 3000	AutoLOC optional with HarvestLab 3000	AutoLOC optional with HarvestLab 3000
AutoTrac or Manual RowSense optional	AutoTrac or Manual RowSense optional	AutoTrac or Manual RowSense optional
Available	Available	Available
Available	Available	Available
Available	Available	Available
Available	Available	Available
Available	Available	Available
—	—	—
Available	Available	Available
Available	Available	Available
Available	Available	Available
Available	Available	Available
Available	Available	Available
Available	Available	Available
Available	Available	Available
Available	Available	Available
21.7 ft (6.6 m)	21.7 ft (6.6 m)	21.7 ft (6.6 m)
10.2-11.5 ft (1.3-3.49 m)	10.2-11.5 ft (1.3-3.49 m)	10.2-11.5 ft (1.3-3.49 m)
Below 13.1 ft (4.0 m)	Below 13.1 ft (4.0 m)	Below 13.1 ft (4.0 m)

# NOTHING RUNS LIKE A DEERE™

As technology like the 9000 Series evolves, and as your business evolves, you can count on one thing: we're there when you need us – for advice, to solve a problem or for a part. Reach out, we'll be there with technicians who are factory trained and ready to go to work for you using only genuine John Deere parts and products.



This literature has been compiled for worldwide circulation. While general information, pictures and descriptions are provided, some illustrations and text may include finance, credit, insurance, product options and accessories not available in all regions. Please contact your local dealer for details. John Deere reserves the right to change specification and design of products described in this literature without notice. The green and yellow color scheme, the leaping deer logo and the JOHN DEERE word mark are trademarks of Deere & Company.